



### Features

- Compliant with IEEE802.3ae 10GBASE-BX Ethernet standard
- Bi-Direction link distance up to 10km
- Simplex LC connector
- Power consumption<1.5W
- Compliant with XFP MSA INF-8077i
- Differential CML inputs and outputs
- Single power supply 3.3V
- TTL signal detect indicator
- Hot Pluggable
- Class 1 laser product complies with EN 60825-1

### Ordering Information

PART NUMBER	INPUT/OUTPUT	SIGNAL DETECT	VOLTAGE	TEMPERATURE
JB1270-XFP-LC.S10	AC/AC	TTL	3.3V	0°C to 70°C
JB1270-XFP-LC.S10(WT)	AC/AC	TTL	3.3V	Option:-25°C to 85°C

### Absolute Maximum Ratings

PARAMETER	SYMBOL	MIN	MAX	UNITS	NOTE
Storage Temperature	$T_S$	-40	85	°C	
Supply Voltage	$V_{CC3}$	-0.5	4.0	V	
Input Voltage	$V_{IN}$	-0.5	$V_{CC}$	V	

**Recommended Operating Conditions**

PARAMETER	SYMBOL	MIN	MAX	UNITS	NOTE
Case operating Temperature	$T_C$	0	70	°C	-25~85°C for JB1270-XFP-LC.S10(WT)
Supply Voltage	$V_{cc3}$	3.1	3.5	V	
Supply Current	$I_{cc3}$	---	600	mA	

**Monitoring Specification**

Data Address	PARAMETER	RANGE	ACCURACY
96-97	Temperature	-10 to 90°C	±3°C
100-101	Bias Current	0 to 100mA	±10%
102-103	TX Power	-7 to +2dBm	±2dB
104-105	RX Power	-16 to 1.5dBm	±2dB
106-107	Vcc3 Voltage	3.0~3.6Volts	±3%

**Transmitter Electro-optical Characteristics**

$V_{cc} = 3.1\text{ V to }3.5\text{ V}$ ,  $T_C = 0\text{ °C to }70\text{ °C}$  for JB1270-XFP-LC.S10

&  $T_C = -25\text{ °C to }85\text{ °C}$  for JB1270-XFP-LC.S10(WT)

PARAMETER	SYMBOL	MIN	TYP.	MAX	UNITS	NOTE
Operating Data Rate		9.95		11.3	Gbps	
Input Reference Clock Rate		Not Required				
Output power	$P_{OUT}$	-5		0	dBm	
Extinction Ratio	$ER$	3.5			dB	
Center Wavelength	$\lambda_c$	1260		1280	nm	
Spectral Width(-20dB)	$\Delta\lambda$			1	nm	
Sidemode Supression ratio	$SSR_{min}$	30			dB	
The transmitter and dispersion penalty	$Tdp$			3.2	dB	
Relative Intensity Noise	$RIN$	---	---	-128	dB/Hz	
Output Eye		Compliant with IEEE802.3ae				
Differential Input Voltage	$V_{DIFF}$	0.25	---	1.0	V	
Transmit Fault Output-Low	$TX\_FAULT_L$	0.0	---	0.5	V	
Transmit Fault Output-High	$TX\_FAULT_H$	2.4	---	$V_{CC}$	V	
TX_DISABLE Assert Time	$t_{off}$	---	---	10	μs	

TX_DISABLE Negate Time	$t_{on}$	---	---	2	ms
Time to initialize	$t_{init}$	---	---	300	ms
Interrupt assert delay	$\overline{\text{Interrupt}}_{on}$	---	---	200	ms
Interrupt negate delay	$\overline{\text{Interrupt}}_{off}$	---	---	500	$\mu\text{s}$
P_Down/RST assert delay	P_Down/RS T_on			100	$\mu\text{s}$
Mod_NR assert delay	Mod_nr_on			1	ms
Mod_NR negate delay	Mod_nr_off			1	ms
P-Down reset time		10			$\mu\text{s}$
RX_LOS assert delay	$t_{loss\_on}$			100	$\mu\text{s}$
RX_LOS negate delay	$t_{loss\_off}$			100	$\mu\text{s}$

**Receiver Electro-optical Characteristics**
 **$V_{CC} = 3.1\text{ V to }3.5\text{ V}$ ,  $T_C = 0^\circ\text{C to }70^\circ\text{C}$  for JB1270-XFP-LC.S10**
**&  $T_C = -25^\circ\text{C to }85^\circ\text{C}$  for JB1270-XFP-LC.S10(WT)**

PARAMETER	SYMBOL	MIN	TYP.	MAX	UNITS	NOTE
Receiver Overload		0.5			dBm	BER < $10^{-12}$
Receiver Sensitivity				-14	dBm	BER < $10^{-12}$
Operating Center Wavelength	$\lambda_C$	1320	---	1340	nm	
Optical Return Loss	$ORL$	14	---	---	dB	
Loss of Signal-Asserted	$P_A$	-30	---	---	dBm	
Loss of Signal-Deasserted	$P_D$	---	---	-18	dBm	
Differential Output Voltage	$V_{DIFF}$	0.5	0.65	0.8	V	
TTL Input High Voltage		2		$V_{CC}$	V	
TTL Input Low Voltage		0		0.8	V	
TTL Output High Voltage		2.4	---	$V_{CC}$	V	
TTL Output Low Voltage		0	---	0.4	V	
Receiver Loss of Signal Assert Time (off to on)	$t_{A,RX\_LOS}$	---	---	100	$\mu\text{s}$	
Receiver Loss of Signal Assert Time (on to off)	$t_{D,RX\_LOS}$	---	---	100	$\mu\text{s}$	

**Serial ID Memory Contents (Table 01h)**

<i>Address</i>	<i>Siz e</i>	<i>Name</i>	<i>Hex</i>	<i>Description</i>
128	1	Identifier	06	XFP
129	1	Ext. Identifier	10	Power consumption<1.5W Tx reference clock not required
130	1	Connector	07	LC Connector
131-138	8	Transceiver	44 40 00 00 00 00 00 00	10G BASE-LR/LW 10GFC 1200-SM-LL-L
139	1	Encoding	D0	64B/66B 8B10B NRZ
140	1	BR-Min	63	9.95Gbps
141	1	BR-Max	71	11.3Gbps
142	1	Length(SMF)-km	0A	10km
143	1	Length(E-50um)	00	0
144	1	Length(50um)	00	0
145	1	Length(62.5um)	00	0
146	1	Length(copper)	00	0
147	1	Device Tech	40	Uncooled DFB, PIN detector
148-163	16	Vendor name	44 61 74 61 20 43 6F 6E 74 72 6F 6C 73 20 20 20	Data Controls
164	1	CDR support	F8	9.95~11.3Gbps
165-167	3	Vender OUI	68 F1 25	
168-183	16	Vendor PN	4A 42 31 32 37 30 58 46 50 4C 43 53 31 30 20 20	JB1270XFPLCS10
184-185	2	Vender rev	xx xx	
186-187	2	Wavelength	63 38	1270nm
188-189	2	Wavelength	07 D0	+/- 10nm

		Tolerance		
190	1	Max Case Temp	46	70degC (JB1270-XFP-LC.S10)
			55	85degC (JB1270-XFP-LC.S10(WT))
191	1	CC_BASE		Check code(128~190)
192-195	4	Power Supply	4B 64 05 00	1.5W (power consumption) 1W (power down mode) 500mA (3.3V)
196-211	16	Vender SN		ASCII
212-219	8	Vender date code	xx xx xx xx xx xx 20 20	ASCII Year(2bytes) , Month(2bytes) , Day(2bytes)
220	1	Diagnostic Monitoring Type	08	No BER support; Average Power
221	1	Enhanced Options	60	Optional soft Tx_disable and P_down
222	1	Aux Monitoring	70	AUX1:+3.3V power supply
223	1	CC_EXT		Check code(192~222)
224-255	32	Vendor specific		Reserved

Block Diagram of Transceiver

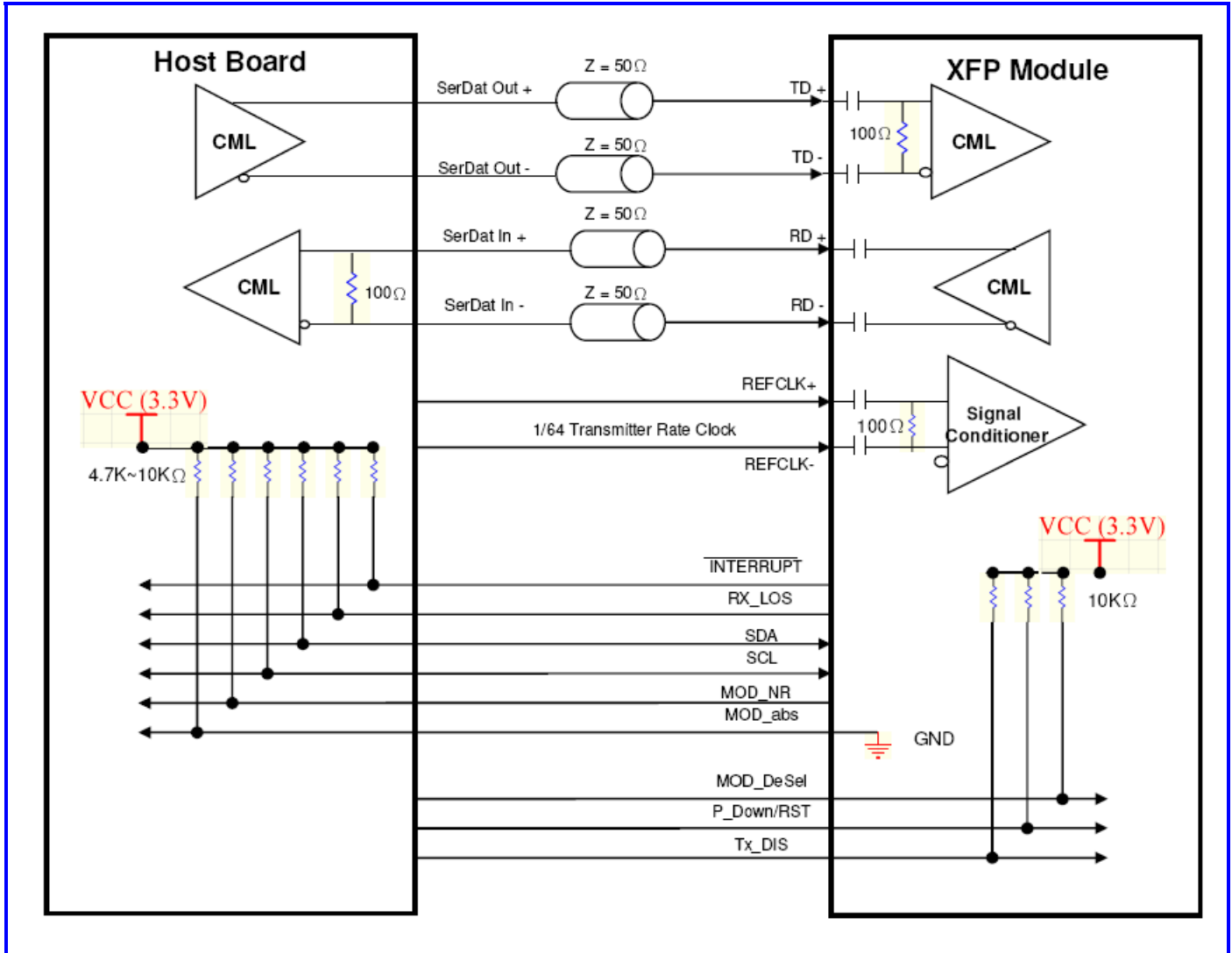

**MOD\_NR**

The Mod\_NR is an output pin that when High, indicates that the module has detected a condition that renders transmitter and or receiver data invalid, shall consist of logical OR of the following signals:

- Transmit Signal Conditioner Loss of Lock
- Transmitter Laser Fault
- Receiver Signal Conditioner Loss of Lock

**MOD\_DeSEL**

The Mod\_DeSel is an input pin. When held Low by the host, the module responds to 2-wire serial communication commands. The Mod\_DeSel allows the use of multiple XFP modules on a single 2-wire interface bus. When the Mod\_DeSel pin is “High”, the module shall not respond to or acknowledge any 2-wire interface communication from the host.

### **INTERRUPT**

Interrupt is an output pin. When “Low”, indicates possible module operational fault or a status critical to the host system.

### **TX\_DIS**

TX\_DIS is an input pin. When TX\_DIS is asserted High, the XFP module transmitter output must be turned off.

### **MOD\_ABS**

Mod\_ABS is pulled up to Host\_Vcc on the host board and grounded in the XFP module. Mod\_ABS is then asserted “High” when the XFP module is physically absent from a host slot.

### **RX\_LOS**

The RX\_LOS when High indicates insufficient optical power for reliable signal reception.

### **P\_DOWN/RST**

This is a multifunction pin for module Power Down and Reset. The P\_Down/RST pin must be pulled up to VCC3 in the XFP module.

### **POWER DOWN FUNCTION**

The P\_Down pin, when held High by the host, places the module in the standby (Low Power) mode with a maximum power dissipation of 1.5W. This protects hosts which are not capable of cooling higher power modules which may be accidentally inserted.

## **Dimensions**



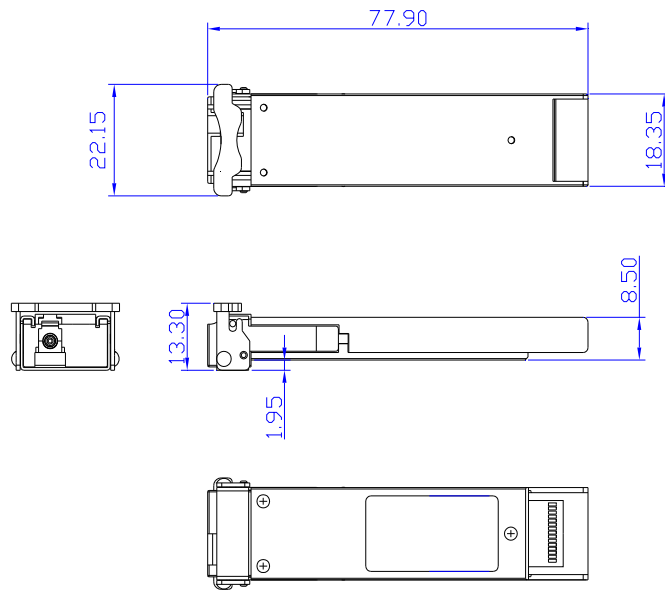

**DIMENSIONS ARE IN MILLIMETERS**

**ALL DIMENSIONS ARE  $\pm 0.2$ mm UNLESS OTHERWISE SPECIFIED**

**Pin Assignment**

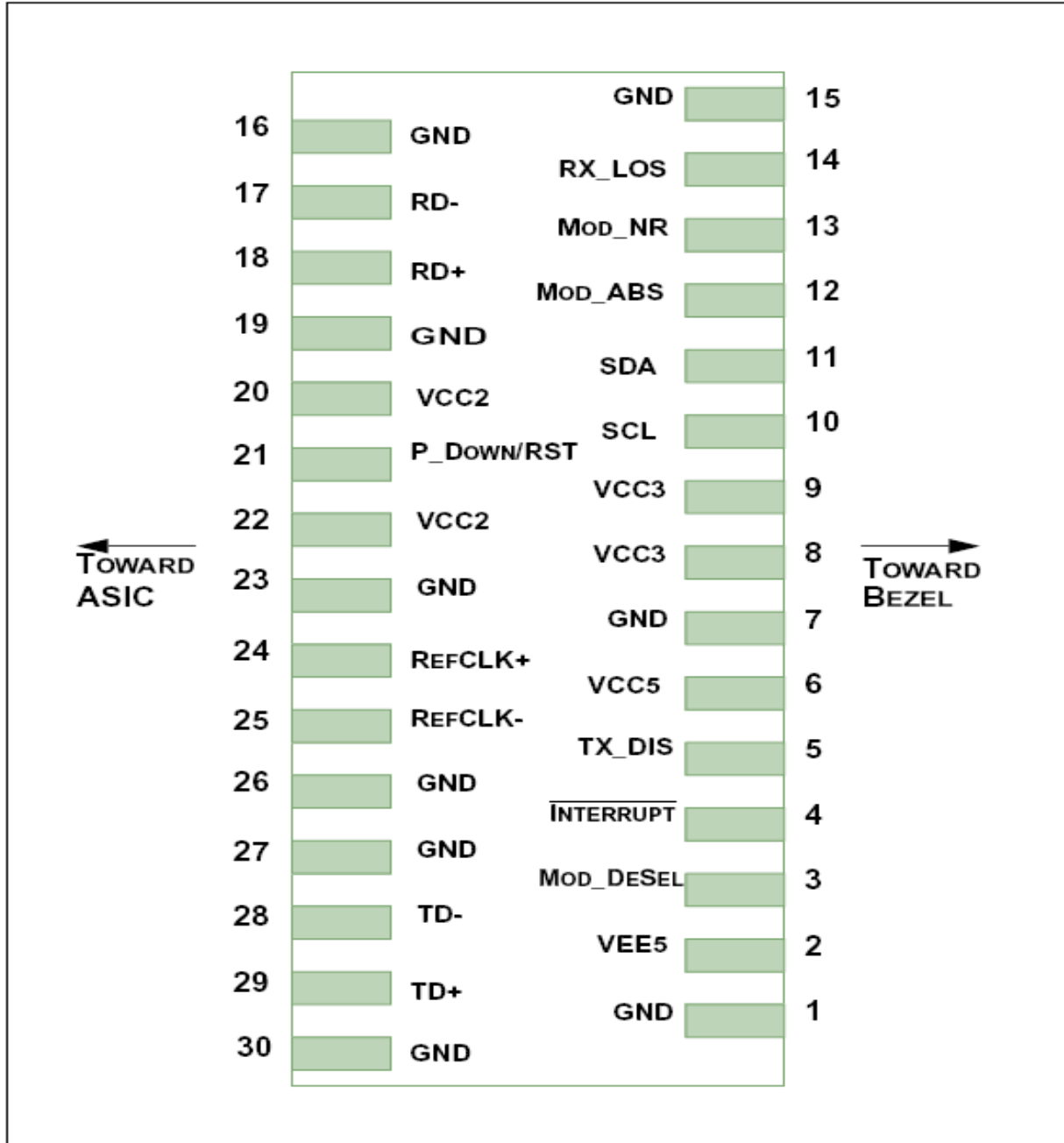

<i>Pin</i>	<i>Logic</i>	<i>Symbol</i>	<i>Name/Description</i>	<i>Note</i>
1		GND	Module Ground	1
2		VEE5	Optional -5.2V Power Supply	
3	LVTTL-I	Mod_DeSel	Module De-select; When held low allows module to respond to 2-wire serial interface	
4	LVTTL-O	$\overline{\text{Interrupt}}$	$\overline{\text{Interrupt}}$ ; Indicates presence of an important condition which can be read over the 2-wire serial interface	2
5	LVTTL-I	TX_DIS	Transmitter Disable; Turns off transmitter laser output	
6		VCC5	+5V Power Supply	
7		GND	Module Ground	1
8		VCC3	+3.3V Power Supply	
9		VCC3	+3.3V Power Supply	
10	LVTTL-I/O	SCL	2-Wire Serial Interface Clock	2
11	LVTTL-I/O	SDA	2-Wire Serial Interface Data Line	2
12	LVTTL-O	Mod_Abs	Indicates Module is not present. Grounded in the Module	2
13	LVTTL-O	Mod_NR	Module Not Ready; Indicating Module Operational Fault	2
14	LVTTL-O	RX_LOS	Receiver Loss Of Signal Indicator	2
15		GND	Module Ground	1
16		GND	Module Ground	1
17	CML-O	RD-	Receiver Inverted Data Output	
18	CML-O	RD+	Receiver Non-Inverted Data Output	
19		GND	Module Ground	1
20		VCC2	+1.8V Power Supply	3
21	LVTTL-I	P_Down/RST	Power down; When high, requires the module to limit power consumption to 1.5W or below. 2-Wire serial interface must be functional in the low power mode. Reset; The falling edge initiates a complete reset of the module including the 2-wire serial interface, equivalent to a power cycle.	
22		VCC2	+1.8V Power Supply	3
23		GND	Module Ground	1
24	PECL-I	RefCLK+	Reference Clock Non-Inverted Input, AC coupled on the host board	
25	PECL-I	RefCLK-	Reference Clock Inverted Input, AC coupled on the host board	
26		GND	Module Ground	1
27		GND	Module Ground	1
28	CML-I	TD-	Transmitter Inverted Data Input	
29	CML-I	TD+	Transmitter Non-Inverted Data Input	
30		GND	Module Ground	1

1. Module ground pins Gnd are isolated from the module case and chassis ground within the module.  
2. Shall be pulled up with 4.7K-10Kohms to a voltage between 3.15V and 3.45V on the host board.  
3. The 1.8 V power supply can be optionally programmed to voltages lower than 1.8 V in modules supporting the variable power supply.

**Eye Safety Mark**

The LS3 series single-mode transceiver is a class 1 laser product. It complies with EN 60825-1 and FDA 21 CFR 1040.10 and 1040.11. In order to meet laser safety requirements the transceiver shall be operated within the Absolute Maximum Ratings.

**Caution**

**All adjustments have been done at the factory before the shipment of the devices. No maintenance and user serviceable part is required. Tampering with and modifying the performance of the device will result in voided product warranty.**

**Required Mark**

Class 1 Laser Product  
Complies with  
21 CFR 1040.10 and 1040.11

Note : All information contained in this document is subject to change without notice.