

# HO850-QSF-MP.M Series

**Multi-Mode 100GBASE-SR4 QSFP28 Transceiver**  
**RoHS6 Compliant**

## Features

- ◆ Supports 103.1Gbps aggregate bit rates
- ◆ Single 3.3V Power Supply and Power dissipation < 3.5W
- ◆ Up to 70m transmission on MMF OM3 and 100m transmission on MMF OM4
- ◆ Hot-Pluggable QSFP28 Footprint
- ◆ Class 1 FDA and IEC60825-1 Laser Safety Compliant
- ◆ RoHS6 Compliant
- ◆ Operating Case Temperature Standard: 0°C~+70°C
- ◆ Compliant with QSFP28 MSA Specification
- ◆ I2C interface with integrated Digital Diagnostic Monitoring



## Applications

- ◆ 100GBASE-SR4 Ethernet

## Ordering Information

Part No.	Data Rate	Distance	Interface	Temp.	DDMI
HO850-QSF-MP.M	103.1Gbps	MMF OM3 for 70m MMF OM4 for 100m	MPO	Standard	Yes

\*The product image only for reference purpose.

**Regulatory Compliance\***

Product Certificate	Certificate Number	Applicable Standard
TUV	R50135086	EN 60950-1:2006+A11+A1+A12+A2
		EN 60825-1:2014
		EN 60825-2:2004+A1+A2
UL	E317337	UL 60950-1
		CSA C22.2 No. 60950-1-07
EMC CE	AE 50285865 0001	EN 55022:2010
		EN 55024:2010
FCC	WTF14F0514417E	47 CFR PART 15 OCT., 2013
FDA	/	CDRH 1040.10
ROHS	/	2011/65/EU

\*The above certificate number updated to June 2014, because some certificate will be updated every year, such as FCC, FDA and ROHS. For the latest certification information, please check with Data Controls Inc..

**Absolute Maximum Ratings\*note1**

Parameter	Symbol	Min.	Max.	Unit
Storage Temperature	Ts	-40	+85	°C
Supply Voltage	Vcc	-0.5	3.6	V
Operating Relative Humidity	RH	5	85	%

Note1: Exceeding any one of these values may destroy the device immediately.

**Recommended Operating Conditions**

Parameter	Symbol		Min.	Typical	Max.	Unit
Operating Case Temperature	Tc	HO850-QSF-MPO.M	0		70	°C
Power Supply Voltage	Vcc		3.135	3.3	3.465	V
Power Consumption	P				3.5	W

**Performance Specifications - Electrical**

Parameter	Symbol	Min.	Typ.	Max	Unit	Notes
<b>Transmitter</b>						
Input Amplitude (Differential)	Vin	150		1050	mVpp	AC coupled inputs*(Note6)
Input Impedance (Differential)	Zin	85	100	115	ohms	Rin > 100 kohms @ DC
<b>Receiver</b>						
Output Amplitude (Differential)	Vout	200		1100	mVpp	AC coupled outputs*(Note6)
Output Impedance (Differential)	Zout	85	100	115	ohms	
Output Rise/Fall Time	tr/ta		12		ps	20%~80%

### Optical and Electrical Characteristics

Parameter	Symbol	Min.	Typical	Max.	Unit
<b>Transmitter</b>					
Signaling Speed per Lane	BRAVE		25.78		Gbps
Data Rate Variation		-100		+100	ppm
Center Wavelength	$\lambda_c$	840	850	860	nm
Average Launch Power, Each Lane*(note2)	Pout/lane	-9.1		2.4	dBm
Optical modulation amplitude	Poma			4	dBm
Extinction Ratio*(Note3)	ER	3			dB
Average launch power of OFF transmitter, per lane				-30	dB
Optical Return Loss Tolerance				12	dB
Transmitter eye mask definition {X1, X2, X3, Y1, Y2, Y3}*(Note4)		IEEE 802.3bm 100Gbase-SR4			
<b>Receiver</b>					
Signaling Speed per Lane	BRAVE		25.78		Gbps
Data Rate Variation		-100		+100	ppm
Center Wavelength	$\lambda_c$	840	850	860	nm
Average Receive Power per Lane	Rpow	-10.3		2.4	dBm
Receive Sensitivity in OMA per Lane*(Note5)	Pmin			-5.2	dBm
Damage Threshold per Lane	Pmax	3.4			dBm
LOS Assert	LOSA	-20			dBm
LOS De-Assert	LOSD			-12	dBm
LOS Hysteresis*(Note6)		0.5			dB

Note2: Output is coupled into a 50/125µm multi-mode fiber.

Note3: Filtered, measured with a PRBS 2<sup>31</sup>-1 test pattern @25.78Gbps

Note4: Filtered, measured with a PRBS 2<sup>31</sup>-1 test pattern @25.78Gbps

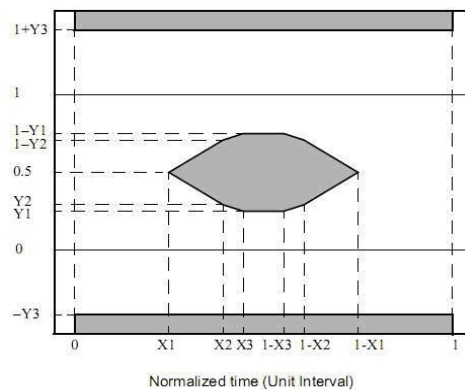

Note5: Minimum average optical power measured at BER less than 1E-12, with a 2<sup>31</sup>-1 PRBS.

Note6: LOS Hysteresis

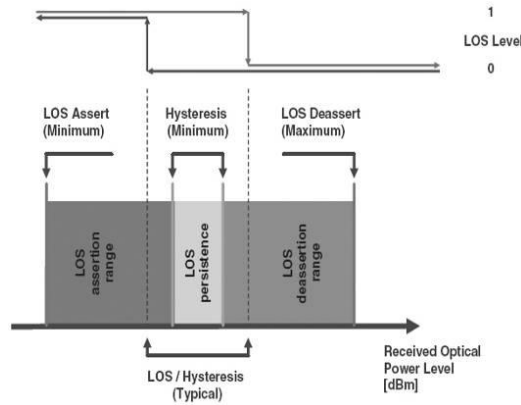

### QSFP28 Transceiver Electrical Pad Layout

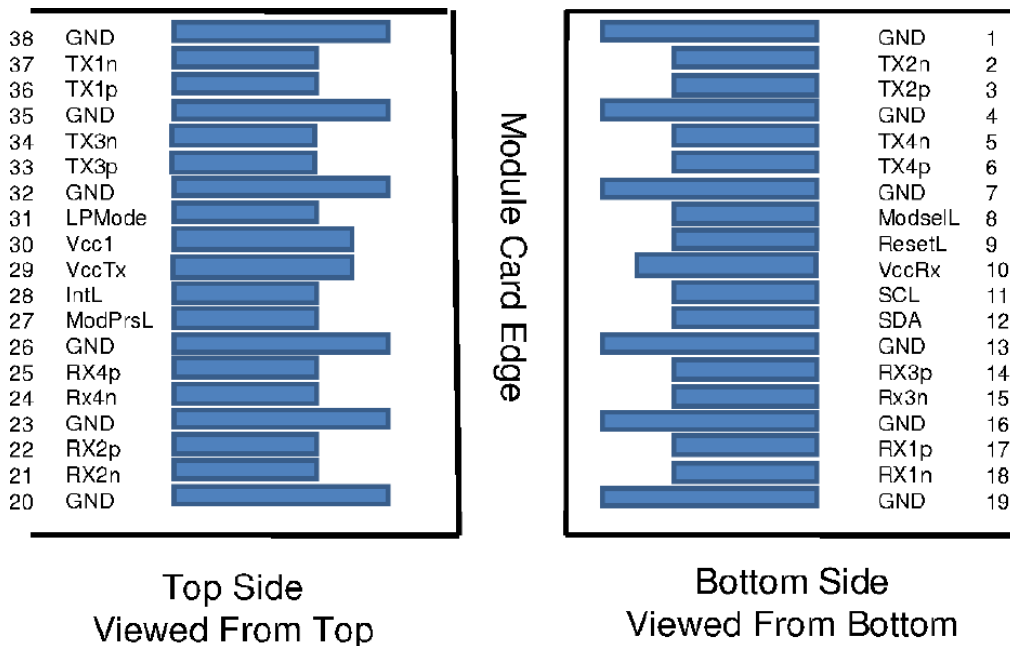

### Pin Function Definitions

Pin	Logic	Symbol	Description	Plug Sequence	Notes
1		GND	Ground	1	1
2	CML-I	Tx2n	Transmitter Inverted Data Input	3	
3	CML-I	Tx2p	Transmitter Non-Inverted Data Input	3	
4		GND	Ground	1	1
5	CML-I	Tx4n	Transmitter Inverted Data Input	3	
6	CML-I	Tx4p	Transmitter Non-Inverted Data Input	3	
7		GND	Ground	1	1
8	LVTTL-I	ModSelL	Module Select	3	
9	LVTTL-I	ResetL	Module Reset	3	
10		VccRx	+3.3V Power Supply Receiver	2	2

11	LVC MOS- I/O	SCL	2-wire serial interface clock	3	
12	LVC MOS- I/O	SDA	2-wire serial interface data	3	
13		GND	Ground	1	1
14	CML-O	Rx3p	Receiver Non-Inverted Data Output	3	
15	CML-O	Rx3n	Receiver Inverted Data Output	3	
16		GND	Ground	1	1
17	CML-O	Rx1p	Receiver Non-Inverted Data Output	3	
18	CML-O	Rx1n	Receiver Inverted Data Output	3	
19		GND	Ground	1	1
20		GND	Ground	1	1
21	CML-O	Rx2n	Receiver Inverted Data Output	3	
22	CML-O	Rx2p	Receiver Non-Inverted Data Output	3	
23		GND	Ground	1	1
24	CML-O	Rx4n	Receiver Inverted Data Output	3	
25	CML-O	Rx4p	Receiver Non-Inverted Data Output	3	
26		GND	Ground	1	1
27	LVTTL-O	ModPrsL	Module Present	3	
28	LVTTL-O	IntL	Interrupt	3	
29		VccTx	+3.3V Power supply transmitter	2	2
30		Vcc1	+3.3V Power supply	2	2
31	LVTTL-I	LPMode	Low Power Mode	3	
32		GND	Ground	1	1
33	CML-I	Tx3p	Transmitter Non-Inverted Data Input	3	
34	CML-I	Tx3n	Transmitter Inverted Data Input	3	
35		GND	Ground	1	1
36	CML-I	Tx1p	Transmitter Non-Inverted Data Input	3	
37	CML-I	Tx1n	Transmitter Inverted Data Input	3	
38		GND	Ground	1	1

1: GND is the symbol for signal and supply (power) common for the QSFP28 module. All are common within the QSFP28 module and all module voltages are referenced to this potential unless otherwise noted. Connect these directly to the host board signal-common ground plane.

2: Vcc Rx, Vcc1 and Vcc Tx are the receiver and transmitter power supplies and shall be applied concurrently. Requirements defined for the host side of the Host Edge Card Connector are listed in Table 6. Recommended host board power supply filtering is shown in Figures 3 and 4. Vcc Rx Vcc1 and Vcc Tx may be internally connected within the QSFP28 Module in any combination. The connector pins are each rated for a maximum current of 500mA.

### Mechanical Specifications

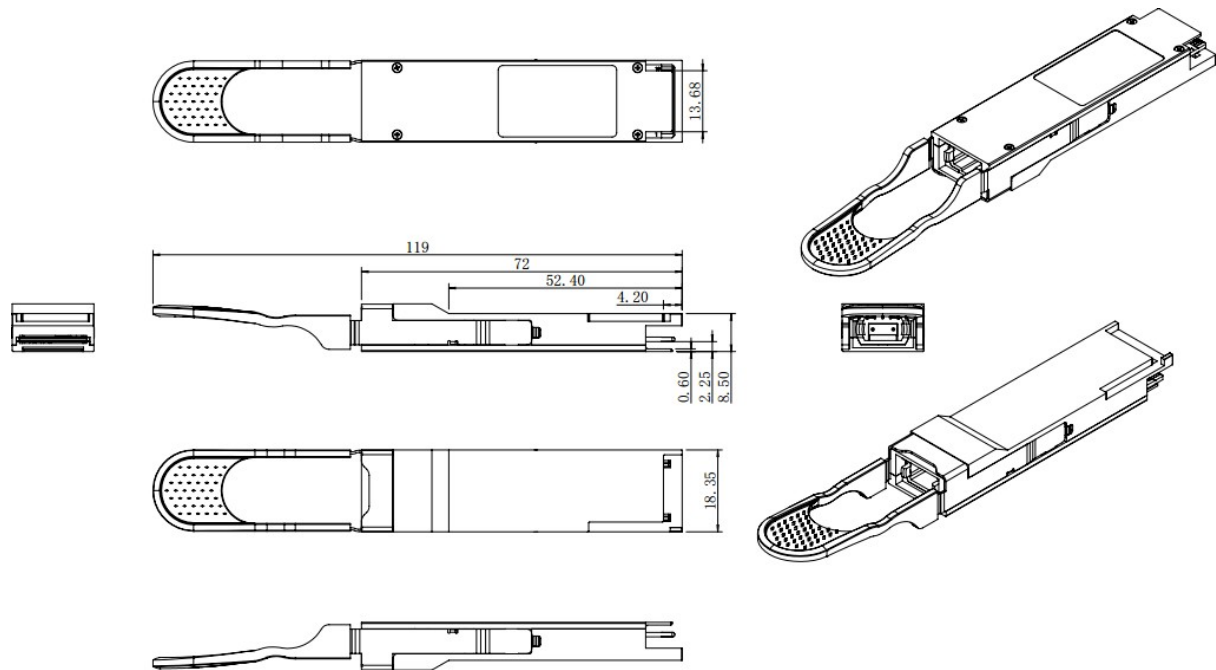

\*This 2D drawing only for reference, please check with Data Controls Inc. before ordering.

### Obtaining Document

You can visit our website <http://www.dci.jp>

Or contact Data Controls Inc. listed at the end of the documentation to get the latest documents.

### Revision History

Revision	Revision History	Release Date
V1.g	Initial Release	Oct. 2017

**Notice:**

Data Controls Inc. reserves the right to make changes or discontinue any optical link product or service identified in this publication, without notice, in order to improve design and/or performance. Applications that are described herein for any of the optical link products are for illustrative purposes only. Data Controls Inc. makes no representation or warranty that such applications will be suitable for the specified use without further testing or modification.

**Contact:****Data Controls Inc.**

E-mail: [sales@dcj.jp](mailto:sales@dcj.jp)

<http://www.dci.jp>