

3Gbps Video Duplex LC SFP 1550nm 80km Transceiver

MSA

VD15509-SFP-LC.S80

Features

- ◆ SMPTE 297-2006 compatible
- ◆ Supports SDI pathological patterns for SD-SDI, HD-SDI, 3G-SDI
- ◆ LC receptacle optical interface compliant
- ◆ Single +3.3V power supply
- ◆ DFB laser and APD photo detector
- ◆ Digital Diagnostic functions available through the I2C interface
- ◆ International Class1 laser safety certified
- ◆ Operating temperature range:
Commercial: -5°C~70°C
Industrial: -40°C~85°C
- ◆ RoHS Compliant

Application

- ◆ SMPTE 297-2006 Compatible Electrical-to-Optical Interfaces
- ◆ HDTV/SDTV Service Interfaces
- ◆ Other Optical Links

Standard

- ◆ Compliant with SFP MSA (INF-8074i)
- ◆ Compliant with SFF-8472
- ◆ Compliant with SMPTE

Ordering Information

Part Number	Specifications					
	Package	Data Rate (Gbps)	Wavelength (nm)	Temperature (°C)	Reach (km)	DDM
VD15509-SFP-LC.S80	SFP	2.97	1550	-5~70	80	Yes
VD15509-SFP-LC.S80(WT)	SFP	2.97	1550	-40~85	80	Yes

Specification

Absolute Maximum Ratings				
Parameter	Symbol	Min	Max	Unit
Storage temperature	TS	-40	85	°C
Power Supply Voltage	V _{CC}	0	3.6	V
Relative Humidity	RH	5	95	%

Recommended Operating Conditions						
Parameter	Symbol	Min	Typical	Max	Unit	Notes
Operating Case Temperature	T _C	-5		70	°C	VD15509-SFP-LC.S80
		-40		85		VD15509-SFP-LC.S80(WT)
Power Supply Voltage	V _{CC}	3.13	3.3	3.47	V	
Data Rate			2.97		Gbps	
Link Budget @9/125μm SMF				80	km	

Electrical Characteristics						
Parameter	Symbol	Min	Typical	Max	Unit	Notes
Total Supply Current	I _{CC}			350	mA	
Transmitter						
Transmitter Differential Input Voltage		400		2400	mV	
Tx_Fault Output Voltage - High	V _{OH}	2.0		V _{CC}	V	LVTTL
Tx_Fault Output Voltage - Low	V _{OL}	0		0.8	V	LVTTL
Tx_Disable Input Voltage - High	V _{IH}	2.0		V _{CC}	V	LVTTL

Tx_Disable Input Voltage - Low	V_{IL}	0		0.8	V	LVTTL
Input Differential Impedance		90	100	110	Ω	
Receiver						
Electrical Characteristics						
Parameter	Symbol	Min	Typical	Max	Unit	Notes
Receiver Differential Output Voltage		650		1000	mV	
LOS Output Voltage - High	V_{OH}	2.0		V_{CC}	V	LVTTL
LOS Output Voltage - Low	V_{OL}	0		0.8	V	LVTTL
Output Differential Impedance		90	100	110	Ω	

Optical Transmitter Characteristics						
Parameter	Symbol	Min	Typical	Max	Unit	Notes
Average Output Power	P_{OUT}	0		5	dBm	
Center Wavelength	λ_c	1530	1550	1570	nm	
Spectral Width(-20dB)	$\Delta\lambda$			1	nm	
Side Mode Suppression Ratio	SMSR	30			dB	
Extinction Ratio	ER	5			dB	
Optical Rise/Fall Time	T_R/T_F			160	ps	
Transmitter OFF Power	P_{OFF}			-45	dBm	
Jitter P-P	T_J			0.1	UI	
Output Eye Diagram	Complies with SMPTE 297-2006					
Optical Receiver Characteristics						
Parameter	Symbol	Min	Typical	Max	Unit	Notes
Center Wavelength	λ_c	1260		1610	nm	
Receiver Sensitivity	@2.97Gbps	P_{SEN}		-28	dBm	
	@1.485Gbps	P_{SEN}		-29	dBm	
	@270Mbps	P_{SEN}		-30	dBm	
Input Saturation Power (Overload)	P_{SAT}	-8			dBm	
LOS De-assert Level	LOSD			-30	dBm	
LOS Assert Level	LOSA	-42			dBm	
LOS hysteresis	HYS	0.5		6	dB	

Note 1. Measured with PRBS2²³-1 pattern, BER=1x10⁻¹².

Pin Definition

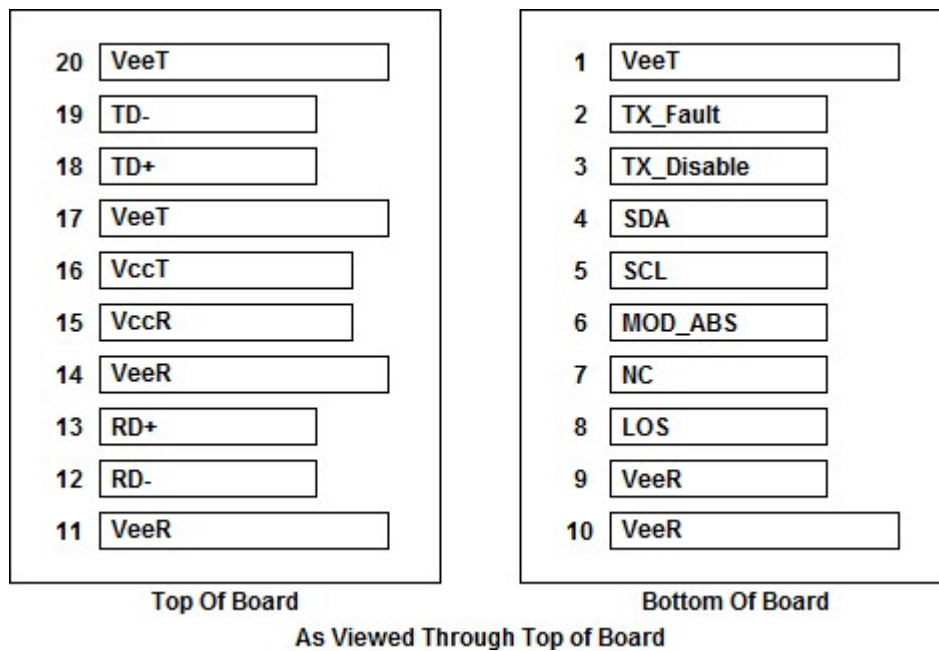

Pin No.	Symbol	Name/Description	Power Seq.	Notes
1	VeeT	Transmitter Ground	1st	
2	TX_Fault	Transmitter Fault Indication, Low: normal; High: abnormal	3rd	1
3	TX_Disable	Transmitter Disable input High: Transmitter off; Low: Transmitter on	3rd	2
4	SDA	I2C Serial Data Signal	3rd	3
5	SCL	I2C Serial Clock Signal	3rd	3
6	MOD_ABS	Module Absent, Grounded in the Module	3rd	4
7	NC	Not Connected	3rd	
8	RX_LOS	Receiver Loss of Signal indication High: loss of signal; Low: signal detected	3rd	5
9	VeeR	Receiver Ground	1st	
10	VeeR	Receiver Ground	1st	
11	VeeR	Receiver Ground	1st	
12	RD-	Inverted Received Data Out, AC coupled	3rd	
13	RD+	Received Data Out, AC coupled	3rd	
14	VeeR	Receiver Ground	1st	
15	VccR	Receiver Power	2nd	

16	VccT	Transmitter Power	2nd	
17	VeeT	Transmitter Ground	1st	
Pin No.	Symbol	Name/Description	Power Seq.	Notes
18	TD+	Transmit Data In, AC coupled	3rd	
19	TD-	Inverted Transmit Data In, AC coupled	3rd	
20	VeeT	Transmitter Ground	1st	

Note1. TX_Fault is an open drain/collector and should be pulled up to Vcc on the host with a 4.7k - 10kΩ resistor.

Note2. TX_Disable is pulled up to Vcc with a 4.7k - 10kΩ resistor inside the module. The states are:

- Low (0 - 0.8V): Transmitter on
- (0.8 - 2.0V): Undefined
- High (2.0 - 3.465V): Transmitter Disabled
- Open: Transmitter Disabled

Note3. SDA&SCL (I2C) shall be pulled up with a 4.7k - 10kΩ resistors on host board.

Note4. Mod_ABS is connected to Ground inside the module.

Note5. RX_LOS is loss of signal indication, shall be pulled up a 4.7k - 10kΩ resistor on host board.

Typical Application Circuit

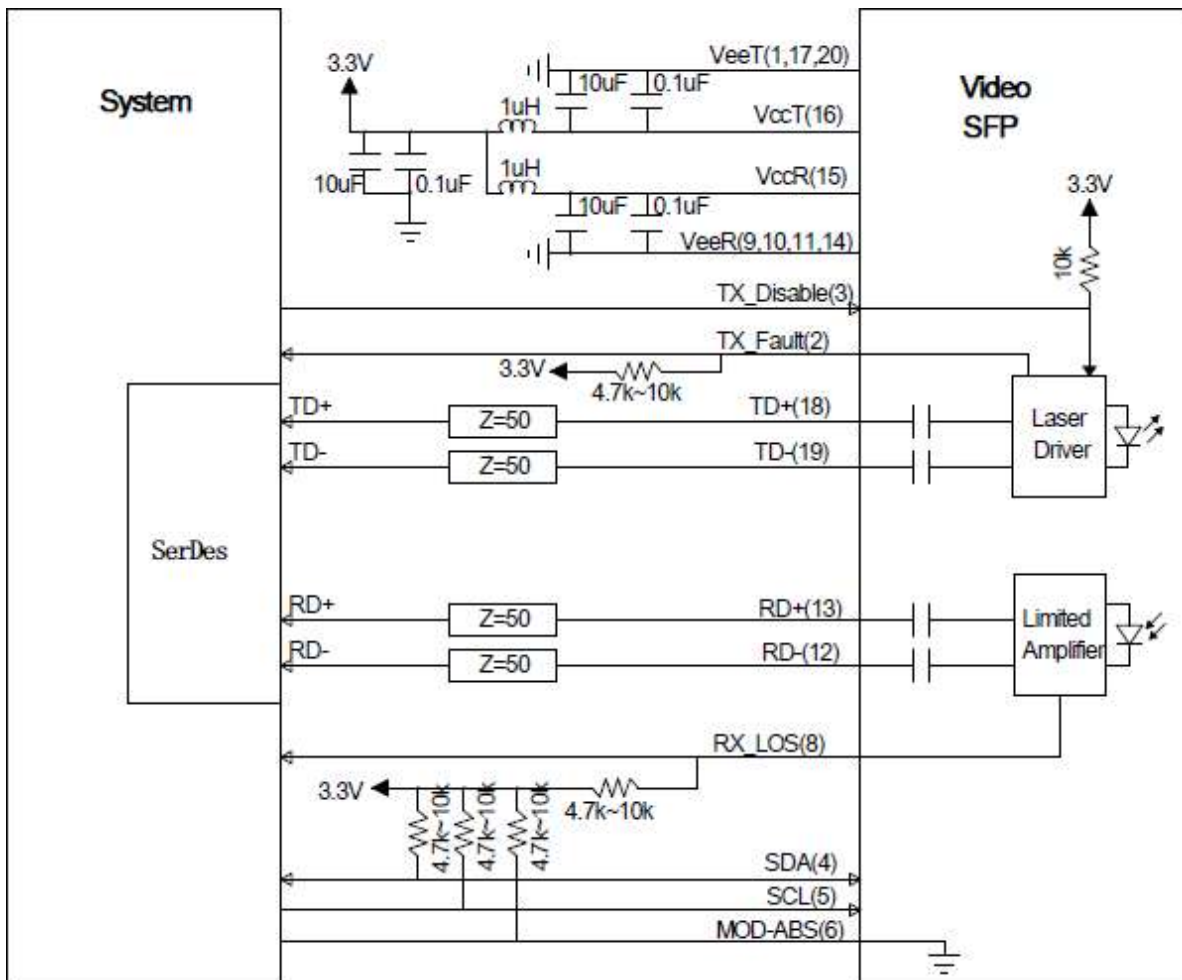

Digital Diagnostic Memory Map

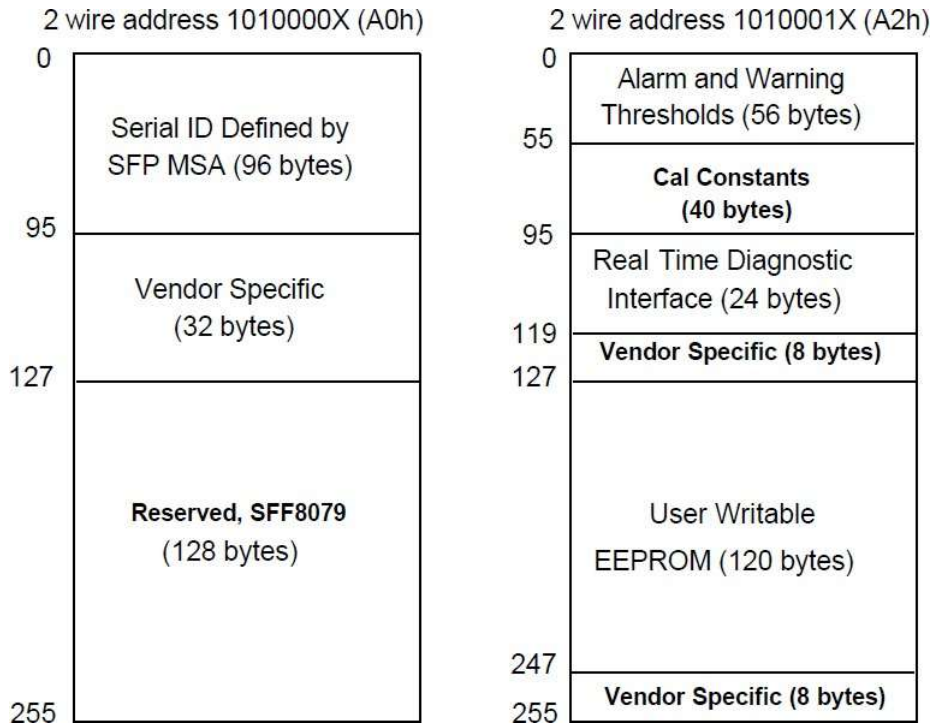

EEPROM Serial ID Memory Contents

The optical transceiver contains an EEPROM. It provides access to sophisticated identification information that describes the transceiver's capabilities, standard interfaces, manufacturer, and other information. When the serial protocol is activated, the host generates the serial clock signal (SCL, Mod Def 1). The positive edge clocks data into those segments of the EEPROM that are not writing protected within the SFP transceiver. The negative edge clocks data from the SFP transceiver. The serial data signal (SDA, Mod Def 2) is bi-directional for serial data transfer. The host uses SDA in conjunction with SCL to mark the start and end of serial protocol activation. The memories are organized as a series of 8-bit data words that can be addressed individually or sequentially.

The Module provides diagnostic information about the present operating conditions. The transceiver generates this diagnostic data by digitization of internal analog signals. Calibration and alarm/warning threshold data is written during device manufacture. Received power monitoring, transmitted power monitoring, bias current monitoring, supply voltage monitoring and temperature monitoring all are implemented. The diagnostic data are raw A/D values and must be converted to real world units using calibration constants stored in EEPROM locations 56 - 95 at wire serial bus address A2h. The digital diagnostic memory map specific data fields define as following.

Package Outline

Dimensions are in millimeters. All dimensions are ± 0.1 mm unless otherwise specified. (Unit: mm)

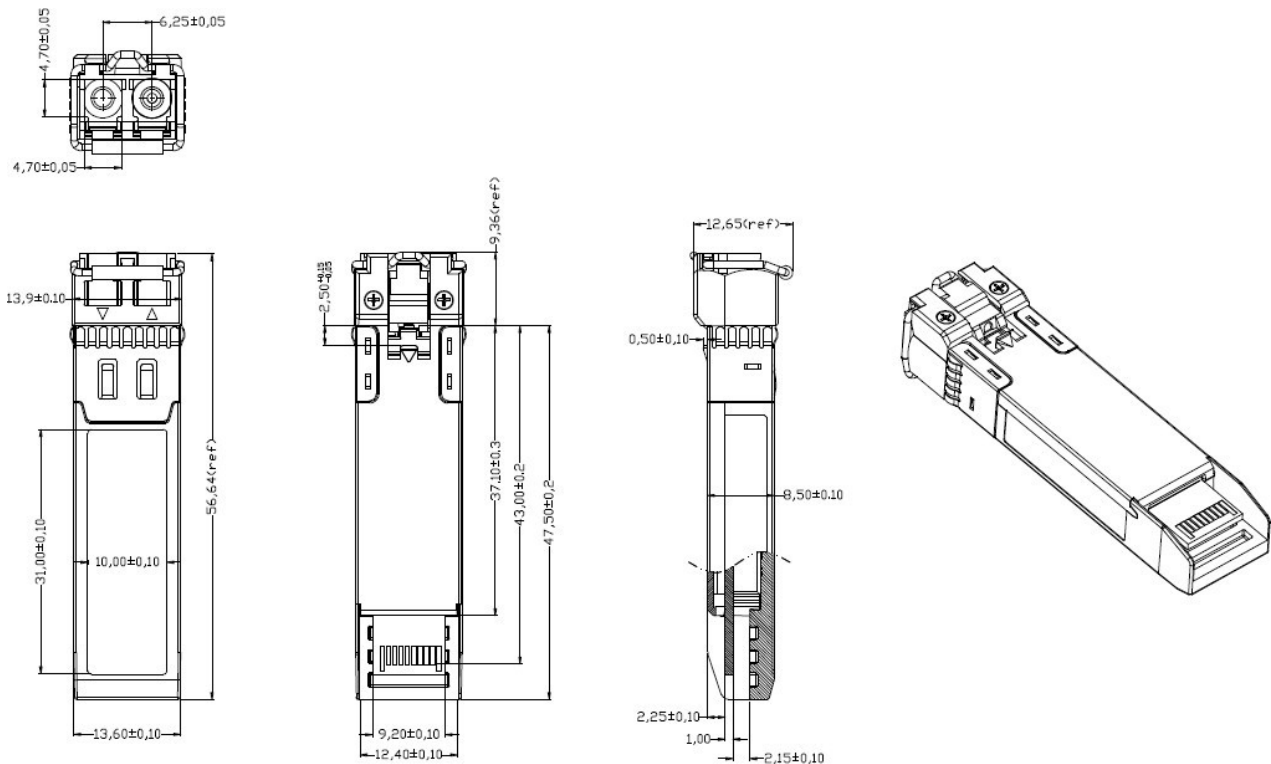

For More Information

Data Controls Inc.

Add: 8F VORT Asakusabashi Ekimae V, 1-20-4 Yanagibashi, Taito-ku, Tokyo 111-0052, Japan

Tel: +81-3-5829-5805

E-mail: sale@dcj.jp

<http://www.dci.jp>