

RoHS Compliant
TX-1310/RX-1550 nm Single-mode Bi-directional (18dB margin)
SFP LC Simplex Connector, with Diagnostic Monitoring
155 Mbps SONET OC-3/SDH STM-1/125 Mbps Fast
Ethernet/100Base-BX10-U/ITU-T G.985



Features

- Compliant with SONET/SDH standard
- Compliant with Fast Ethernet standard
- Industry standard small form pluggable (SFP) package
- Simplex LC connector
- Differential LVPECL inputs and outputs
- Single power supply 3.3V
- TTL signal detect indicator
- Hot Pluggable
- Class 1 laser product complies with EN 60825-1

Ordering Information

PART NUMBER	TX/RX	TEMPERATURE	LD Type	Distance
DB1310-SFP-LC.S20	1310/1550	0°C to 70°C	1310 FP	20km
DB1310-SFP-LC.S20(WT)	1310/1550	-40°C to 85°C	1310 FP	20km

Diagnostics

Parameter	Range	Accuracy	Unit	Calibration
Temperature	-40 to 95	± 3	°C	External
Voltage	3.0 to 3.6	± 0.1	V	
Bias Current	0 to 100	± 5	mA	
TX Power	-17 to -5	± 3 dB	dBm	
RX Power	-31 to -8	± 3 dB	dBm	

RoHS Compliant
TX-1310/RX-1550 nm Single-mode Bi-directional (18dB margin)
SFP LC Simplex Connector, with Diagnostic Monitoring
155 Mbps SONET OC-3/SDH STM-1/125 Mbps Fast
Ethernet/100Base-BX10-U/ITU-T G.985

Absolute Maximum Ratings

PARAMETER	SYMBOL	MIN	MAX	UNITS	NOTE
Storage Temperature	T_S	-40	85	°C	
Supply Voltage	V_{CC}	-0.5	4.0	V	
Input Voltage	V_{IN}	-0.5	V_{CC}	V	
Output Current	I_o	---	50	mA	
Operating Current	I_{OP}	---	400	mA	

Recommended Operating Conditions

PARAMETER	SYMBOL	MIN	MAX	UNITS	NOTE
Case Operating Temperature	T_C	<u>0</u>	<u>70</u>	°C	DB1310-SFP-LC.S20
		-40	85	°C	DB1310-SFP-LC.S20(WT)
Supply Voltage	V_{CC}	3.1	3.5	V	
Supply Current	$I_{TX} + I_{RX}$	---	200	mA	

Transmitter Electro-optical Characteristics

$V_{CC} = 3.1 \text{ V to } 3.5 \text{ V}$, $T_C = 0^\circ \text{ C to } 70^\circ \text{ C}$ ($-40^\circ \text{ C to } 85^\circ \text{ C}$)

PARAMETER	SYMBOL	MIN	TYP.	MAX	UNITS	NOTE
Output Optical Power 9/125 μm fiber	P_{out}	-14	---	-8	dBm	Average
Extinction Ratio	ER	8.2	---	---	dB	
Center Wavelength	λ_C	1261	1310	1360	nm	
Spectral Width (RMS)	$\Delta\lambda$	---	---	4	nm	
Rise/Fall Time (10–90%)	$T_{r,f}$	---	1	2	ns	
Output Eye	Compliant with Telcordia GR-253-CORE Issue 3 and ITU-T recommendation G-957					
Max. P_{out} TX-DISABLE Asserted	P_{OFF}	---	---	-45	dBm	
Differential Input Voltage	V_{DIFF}	0.4	---	2.0	V	
Transmit Fault Output-Low	TX_FAULT_L	0.0	---	0.5	V	
Transmit Fault Output-High	TX_FAULT_H	2.4	---	V_{CC}	V	
Time to initialize, include reset of TX_FAULT	t_{init}	---	---	300	ms	
TX_FAULT from fault to assertion	t_{fault}	---	---	100	μs	

Receiver Electro-optical Characteristics

$V_{CC} = 3.1 \text{ V to } 3.5 \text{ V}, T_C = 0^\circ \text{ C to } 70^\circ \text{ C} (-40^\circ \text{ C to } 85^\circ \text{ C})$

PARAMETER	SYMBOL	MIN	TYP.	MAX	UNITS	NOTE
Optical Input Power-maximum	P_{IN}	0	---	---	dBm	BER < 10^{-10}
RX Sensitivity @OC-3	P_{IN}	---	---	-32	dBm	PRBS23, BER < 10^{-10}
RX Sensitivity @125Mbps	P_{IN}	---	---	-32	dBm	PRBS7, BER < 10^{-10}
Operating Center Wavelength	λ_C	1480	---	1600	nm	
Optical Return Loss	ORL	14	---	---	dB	$\lambda=1480\sim1600\text{nm}$
Optical isolation	ISO	---	---	-45	dB	$\lambda=1260\sim1360\text{nm}$
Loss of signal-Asserted	P_A	---	---	-32	dBm	
Loss of signal-Deasserted	P_D	-45	---	---	dBm	
Differential Output Voltage	V_{DIFF}	0.5	---	1.2	V	
Receiver Loss of Signal Output Voltage-Low	RX_LOS_L	0	---	0.5	V	
Receiver Loss of Signal Output Voltage-High	RX_LOS_H	2.4	---	V_{CC}	V	

Block Diagram of Transceiver

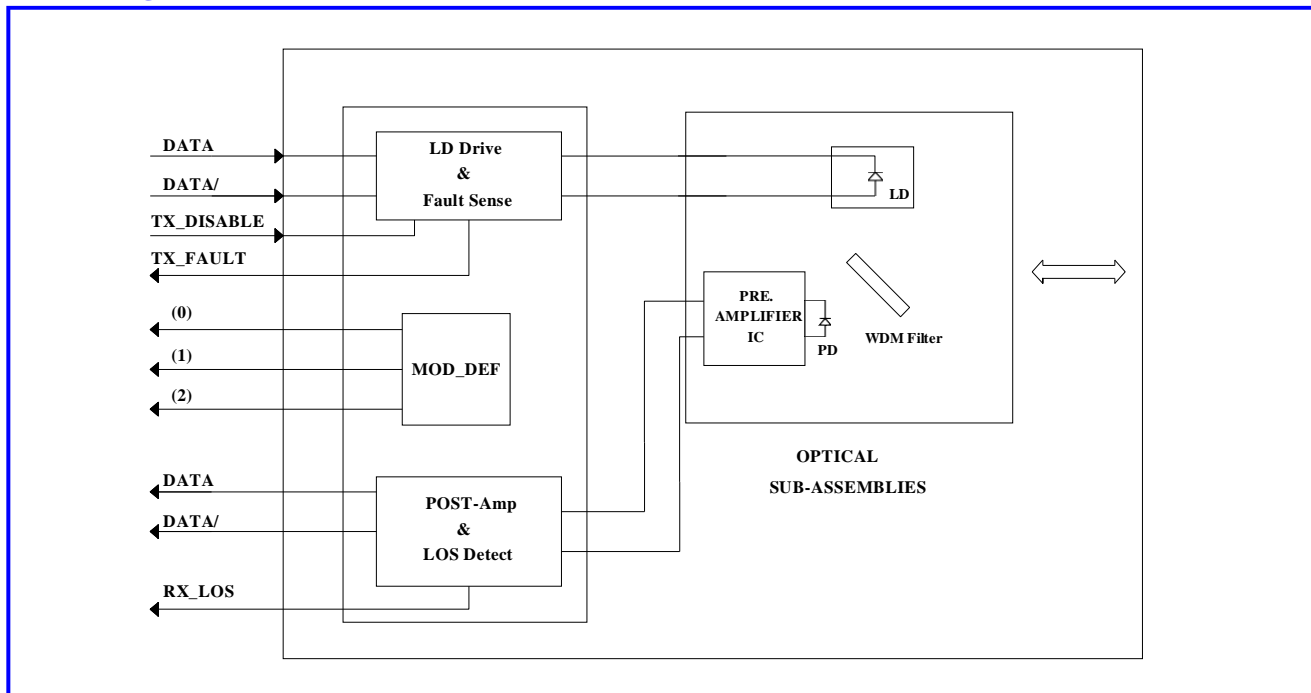

Transmitter and Receiver Optical Sub-assembly Section

A 1310 nm InGaAsP laser and an InGaAs PIN photodiode integrate with an WDM filter to form a bi-directional single fiber optical subassembly (OSA). The laser of OSA is driven by a LD driver IC which converts differential input LVPECL logic signals into an analog laser driving current. And, The photodiode of OSA is connected to a circuit providing post-amplification quantization, and optical signal detection.

TX_FAULT

When sensing an improper power level in the laser driver, the SFP set this signal high and turns off the Laser. TX_FAULT can be reset with the TX_DISABLE line. The signal is in TTL level.

TX_DISABLE

The TX_DISABLE signal is high (TTL logic "1") to turn off the laser output.

Receive Loss (RX_LOS)

The RX_LOS is high (logic "1") when there is no incoming light from the companion transceiver. This signal is normally used by the system for the diagnostic purpose. The signal is operated in TTL level.

Dimensions

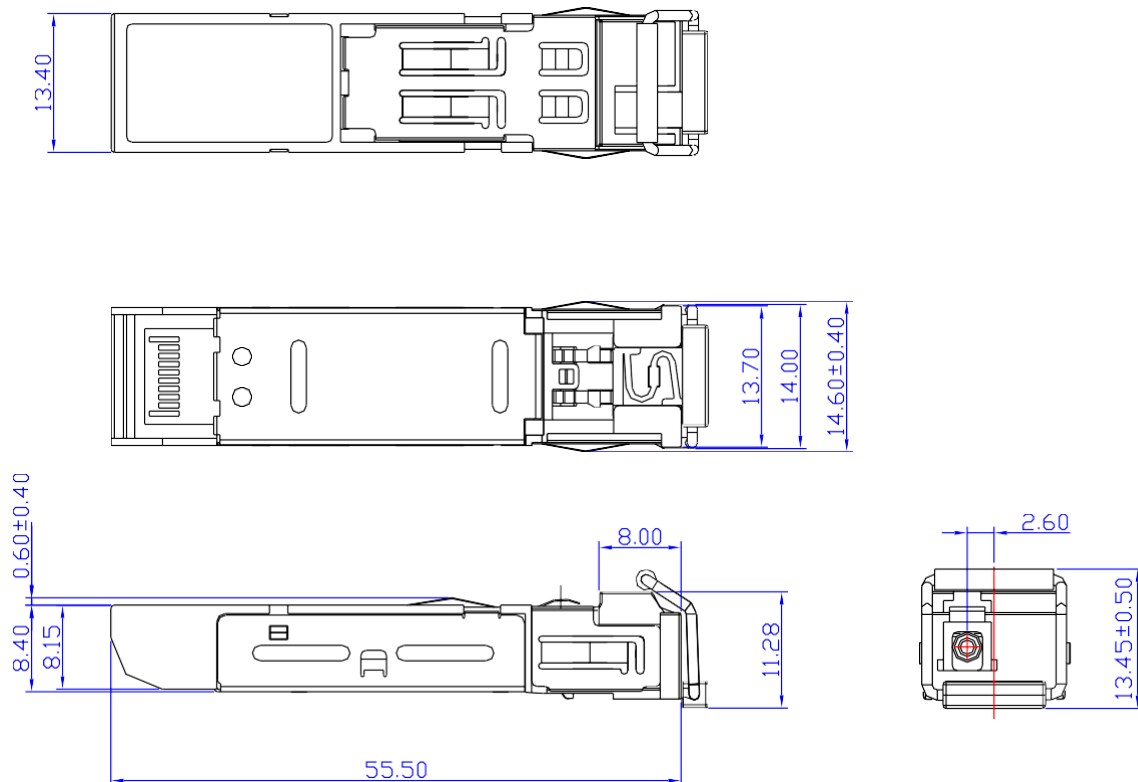

DIMENSIONS ARE IN MILLIMETERS

ALL DIMENSIONS ARE ±0.2mm UNLESS OTHERWISE SPECIFIED

RoHS Compliant
TX-1310/RX-1550 nm Single-mode Bi-directional (18dB margin)
SFP LC Simplex Connector, with Diagnostic Monitoring
155 Mbps SONET OC-3/SDH STM-1/125 Mbps Fast
Ethernet/100Base-BX10-U/ITU-T G.985

SFP host board mechanical layout

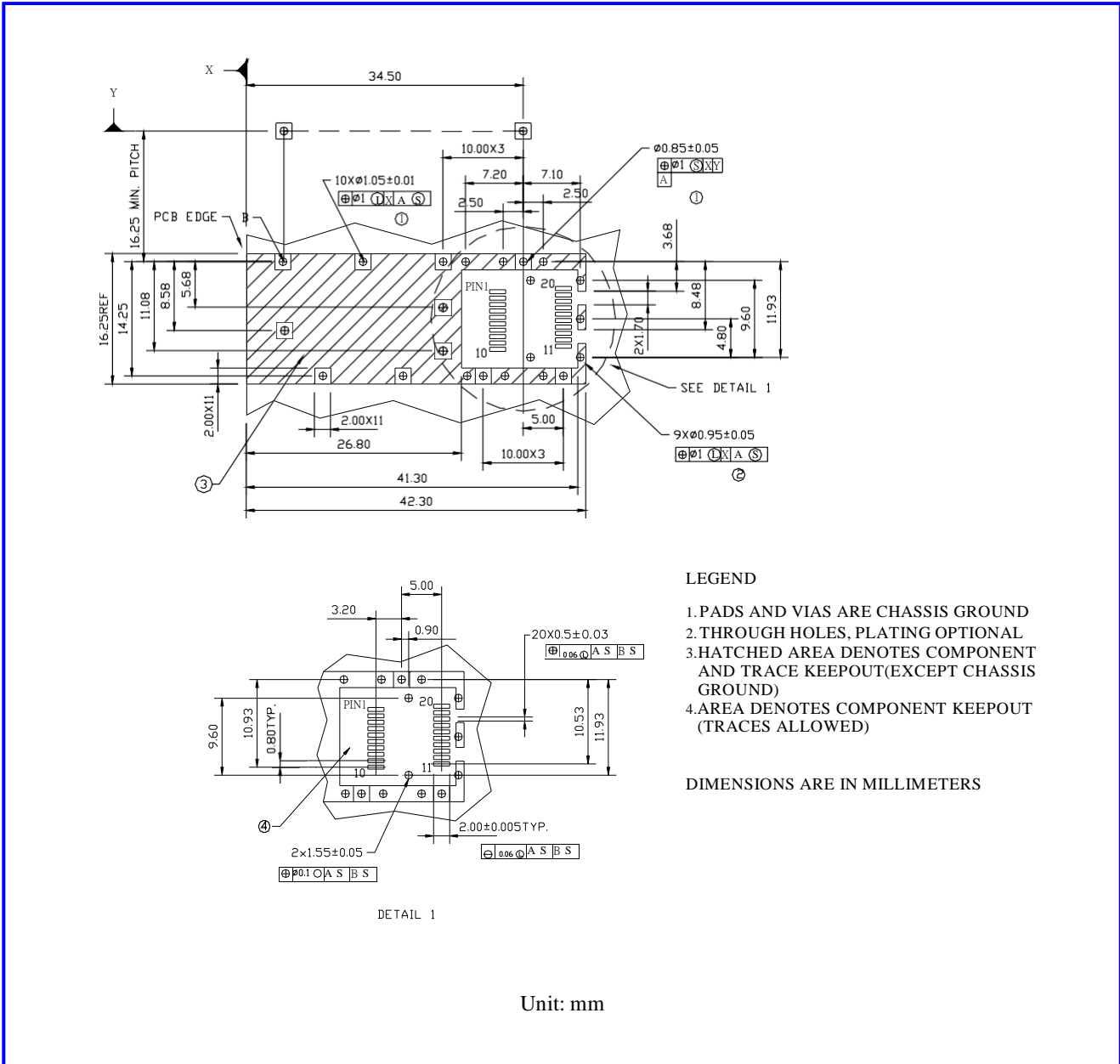

Assembly drawing

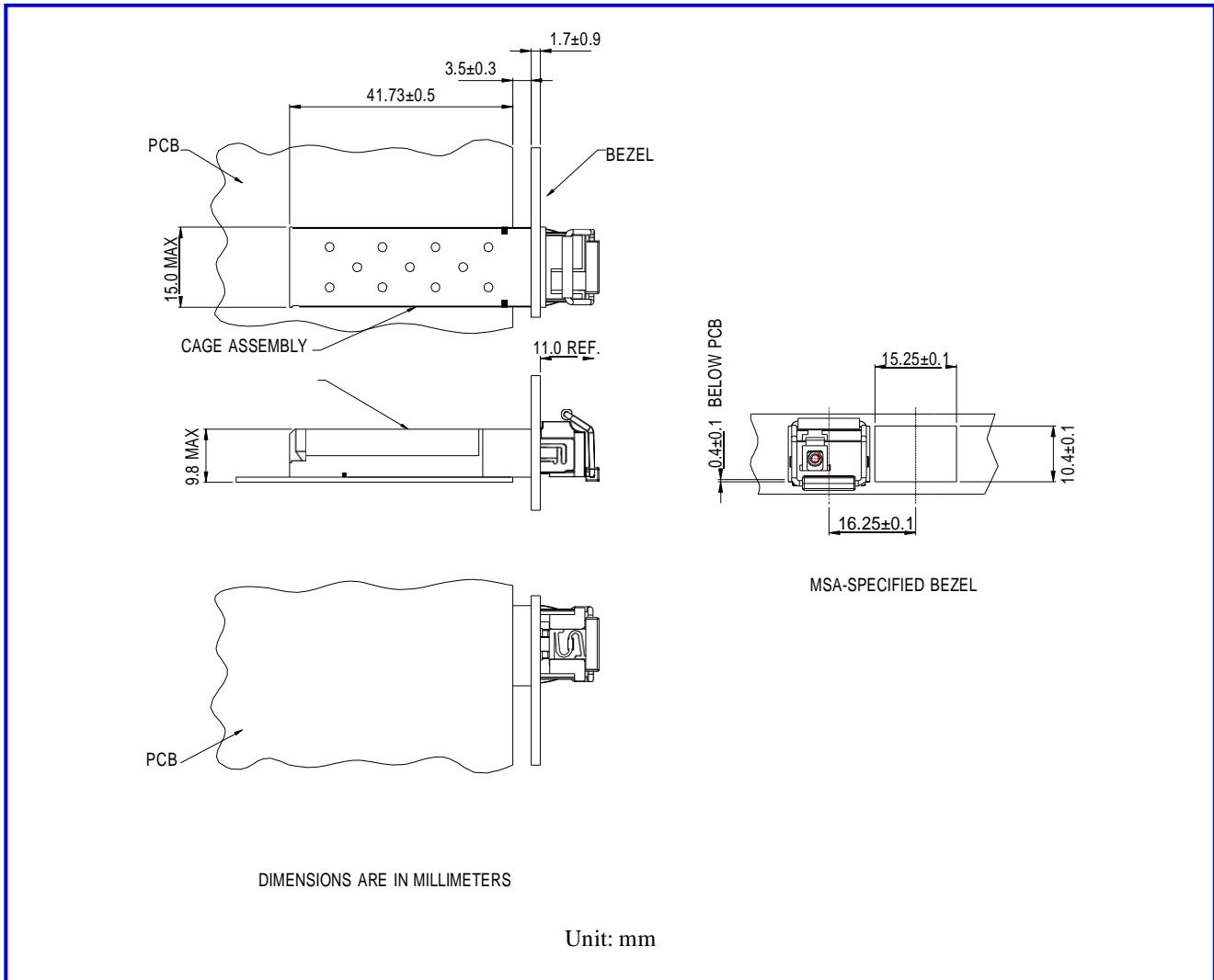

Pin Assignment

Pin-Out

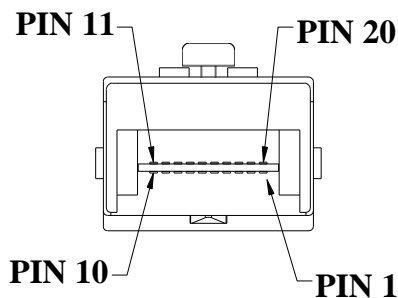

Pin	Signal Name	Description
1	T_{GND}	Transmit Ground
2	TX_FAULT	Transmit Fault
3	$TX_DISABLE$	Transmit Disable
4	$MOD_DEF (2)$	SDA Serial Data Signal
5	$MOD_DEF (1)$	SCL Serial Clock Signal
6	$MOD_DEF (0)$	TTL Low
7	$RATE_SELECT$	Open Circuit
8	RX_LOS	Receiver Loss of Signal, TTL High, open collector
9	R_{GND}	Receiver Ground
10	R_{GND}	Receiver Ground
11	R_{GND}	Receiver Ground
12	$RX-$	Receive Data Bar, Differential PECL, ac coupled
13	$RX+$	Receive Data, Differential PECL, ac coupled
14	R_{GND}	Receiver Ground
15	V_{CCR}	Receiver Power Supply
16	V_{CCT}	Transmitter Power Supply
17	T_{GND}	Transmitter Ground
18	$TX+$	Transmit Data, Differential PECL, ac coupled
19	$TX-$	Transmit Data Bar, Differential PECL, ac coupled
20	T_{GND}	Transmitter Ground

Note : All information contained in this document is subject to change without notice.