

## DB1xx0-SFP-LC.S80/120/140 Series

**Single-Mode 155Mbps SDH /SONET  
Simplex LC Single-Fiber SFP Transceiver  
RoHS6 Compliant**



### Features

- ◆ Support 155Mbps data links
- ◆ CWDM DFB LD Transmitterfrom
- ◆ Single 3.3V Power supply and TTL Logic Interface
- ◆ Hot-Pluggable SFP
- ◆ Class 1 FDA and IEC60825-1 laser safety compliant
- ◆ Operating Case Temperature

Standard: 0°C~+70°C

Extended: -20°C~+85°C

- ◆ Compliant with SFP MSA
- ◆ Compliant with SFF-8472

### Applications

- ◆ SONET OC-3 / SDH STM-1
- ◆ WDM Fast Ethernet Links

### Ordering information

Part No.	Data Rate	Power budget	Interface	Temp.	DDMI
DB1xx0-SFP-LC.S80	100M~155Mbps	≥29dB	LC	Standard	YES
DB1xx0-SFP-LC.S80(WT)	100M~155Mbps	≥29dB	LC	Extended	YES
DB1xx0-SFP-LC.S120	100M~155Mbps	≥34dB	LC	Standard	YES
DB1xx0-SFP-LC.S120(WT)	100M~155Mbps	≥34dB	LC	Extended	YES
DB1xx0-SFP-LC.S140	100M~155Mbps	≥36dB	LC	Standard	YES
DB1xx0-SFP-LC.S140(WT)	100M~155Mbps	≥36dB	LC	Extended	YES

\*The product image only for reference purpose.

**Regulatory Compliance\***

Product Certificate	Certificate Number	Applicable Standard
TUV	R50135086	EN 60950-1:2006+A11+A1+A12+A2
		EN 60825-1:2014
		EN 60825-2:2004+A1+A2
UL	E317337	UL 60950-1
		CSA C22.2 No. 60950-1-07
EMC CE	AE 50384190 0001	EN 55032:2012
		EN 55032:2015
		EN 55024:2010
		EN 55024:2010+A1
FCC	WTF14F0514417E	47 CFR PART 15 OCT., 2013
FDA	/	CDRH 1040.10
ROHS	/	2011/65/EU

\*The above certificate number updated to June 2018, because some certificate will be updated every year, such as FDA and ROHS. For the latest certification information, please check with Data Controls.

**Product Description**

The DB1xx0-SFP-LC.S80/120/140 series is small form factor pluggable module for IEEE 802.3ah 1000BASE-BX and OC-3/STM-1 SONET/SDH single fiber communications. It is with the SFP 20-pin connector to allow hot plug capability.

The DB1xx0-SFP-LC.S80/120/140 series are designed to be compliant with SFF-8472.

**Absolute Maximum Ratings<sup>\*note2</sup>**

Parameter	Symbol	Min.	Max.	Unit
Storage Temperature	T <sub>s</sub>	-40	+85	°C
Supply Voltage	V <sub>cc</sub>	-0.5	3.6	V
Operating Relative Humidity		-	95	%

Note2: Exceeding any one of these values may destroy the device immediately.

**Recommended Operating Conditions**

Parameter	Symbol	Min.	Typical	Max.	Unit
Operating Case Temperature	T <sub>c</sub>	DB1xx0-SFP-LC.Sxx	0	+70	°C
		DB1xx0-SFP-LC.Sxx(WT)	-20	+85	
Power Supply Voltage	V <sub>cc</sub>	3.15	3.3	3.45	V
Power Supply Current	I <sub>cc</sub>			300	mA
Data Rate	OC-3		155		Mbps
	100M		100		Mbps

**Performance Specifications – Electrical**

Parameter	Symbol	Min.	Typ.	Max	Unit	Notes
<b>Transmitter</b>						
LVPECL Inputs(Differential)	Vin	400		2000	mVpp	AC coupled inputs*(note5)
Input Impedance (Differential)	Zin	85	100	115	ohms	Rin > 100 kohms @ DC
Tx_Dis	Disable	2		Vcc	V	
	Enable	0		0.8		
Tx_FAULT	Fault	2		Vcc+0.3	V	
	normal	0		0.5		
<b>Receiver</b>						
LVPECL Outputs (Differential)	Vout	370		2000	mVpp	AC coupled outputs*(note5)
Output Impedance (Differential)	Zout	85	100	115	ohms	
Rx_LOS	LOS	2		Vcc+0.3	V	
	normal	0		0.8	V	
MOD_DEF ( 0:2 )	VoH	2.5			V	With Serial ID
	VoL	0		0.5	V	

**Performance Specifications – Optical**

(CWDM DFB and PIN-TIA with 29dB Power Budget)

Parameter	Symbol	Min.	Typical	Max.	Unit
Power budget		29			dB
Data Rate			100/155		Mbps
<b>Transmitter</b>					
Channel Centre Wavelength*(note9)		$\lambda_c-6$	$\lambda_c$	$\lambda_c+7.5$	nm
Spectral Width (-20dB)	$\Delta\lambda$			1	nm
Side Mode Suppression Ratio	SMSR	30			dB
Average Output Power*(note3)	Pout	-5		0	dBm
Extinction Ratio*(note4)	ER	10			dB
Rise/Fall Time(20%~80%)	tr/tf			2	ns
Output Optical Eye*(note4)	IUT-T G.957 Compliant*(note7)				
TX_Disable Assert Time	t_off			10	Us
<b>Receiver</b>					
Channel Centre Wavelength*(note9)		1260		1630	nm
Receiver Sensitivity*(note6)	OC-3	Pmin		-34	dBm
	100M			-35	dBm
Receiver Overload	Pmax	-10			dBm
Return Loss		12			dB
Optical Path Penalty				1	dB

LOS De-Assert	LOSD			-36	dBm
LOS Assert	LOSA	-45			dBm
LOS Hysteresis <sup>*(note8)</sup>		0.5			dB

**(CWDM DFB and PIN-TIA with 34dB Power Budget)**

Parameter	Symbol	Min.	Typical	Max.	Unit
Power budget		34			dB
Data Rate			100/155		Mbps
<b>Transmitter</b>					
Channel Centre Wavelength <sup>*(note9)</sup>		$\lambda_{c-6}$	$\lambda_c$	$\lambda_{c+7.5}$	nm
Spectral Width (-20dB)	$\Delta\lambda$			1	nm
Side Mode Suppression Ratio	SMSR	30			dB
Average Output Power <sup>*(note3)</sup>	P <sub>out</sub>	0		5	dBm
Extinction Ratio <sup>*(note4)</sup>	ER	10			dB
Rise/Fall Time(20%~80%)	tr/tf			2	ns
Output Optical Eye <sup>*(note4)</sup>	IUT-T G.957 Compliant <sup>*(note7)</sup>				
TX_Disable Assert Time	t <sub>off</sub>			10	Us
<b>Receiver</b>					
Channel Centre Wavelength <sup>*(note9)</sup>		1260		1630	nm
Receiver Sensitivity @ EOL <sup>*(note6)</sup>	OC-3	P <sub>min, EOL</sub>		-34	dBm
	100M			-35	dBm
Receiver Overload	P <sub>max</sub>	-10			dBm
Return Loss		12			dB
Optical Path Penalty				1	dB
LOS De-Assert	LOSD			-36	dBm
LOS Assert	LOSA	-45			dBm
LOS Hysteresis <sup>*(note8)</sup>		0.5			dB

**(CWDM DFB and PIN-TIA with 36dB Power Budget)**

Parameter	Symbol	Min.	Typical	Max.	Unit
Power budget		36			dB
Data Rate			100/155		Mbps
<b>Transmitter</b>					
Channel Centre Wavelength <sup>*(note9)</sup>		$\lambda_{c-6}$	$\lambda_c$	$\lambda_{c+7.5}$	nm
Spectral Width (-20dB)	$\Delta\lambda$			1	nm
Side Mode Suppression Ratio	SMSR	30			dB
Average Output Power <sup>*(note3)</sup>	P <sub>out</sub>	+1		+5	dBm
Extinction Ratio <sup>*(note4)</sup>	ER	10			dB
Rise/Fall Time(20%~80%)	tr/tf			2	ns
Output Optical Eye <sup>*(note4)</sup>	IUT-T G.957 Compliant <sup>*(note7)</sup>				
TX_Disable Assert Time	t <sub>off</sub>			10	Us
<b>Receiver</b>					
Channel Centre Wavelength <sup>*(note9)</sup>		1260		1630	nm
Receiver Sensitivity @	OC-3			-35	dBm

EOL *(note6)	100M				-36	dBm
Receiver Overload		Pmax	-10			dBm
Return Loss			12			dB
Optical Path Penalty					1	dB
LOS De-Assert		LOSD			-37	dBm
LOS Assert		LOSA	-45			dBm
LOS Hysteresis*(note8)			0.5			dB

Note3: Output is coupled into a 9/125µm single-mode fiber.

Note4: Filtered, measured with a PRBS 2<sup>23</sup>-1 test pattern @155Mbps

Note5: LVPECL logic, internally AC coupled.

Note6: Minimum average optical power measured at the BER less than 1E-10 with a 2<sup>23</sup>-1 PRBS and ER=9 dB.

Note7: Eye pattern mask

Note8: LOS Hysteresis

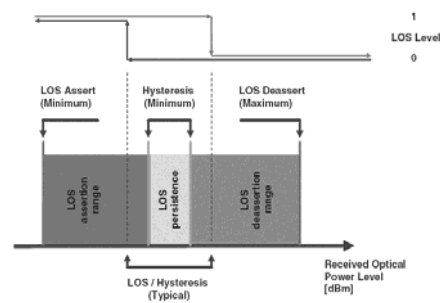
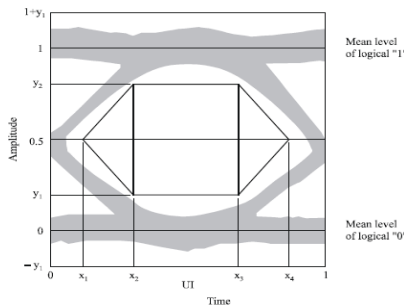

Note9: The channel center wavelength of transmitter side is compliant with table <CWDM\* Wavelength>, and the channel center wavelength of receiver side is the typical wavelength of CWDM channel ±20nm.

## Functional Description of Transceiver

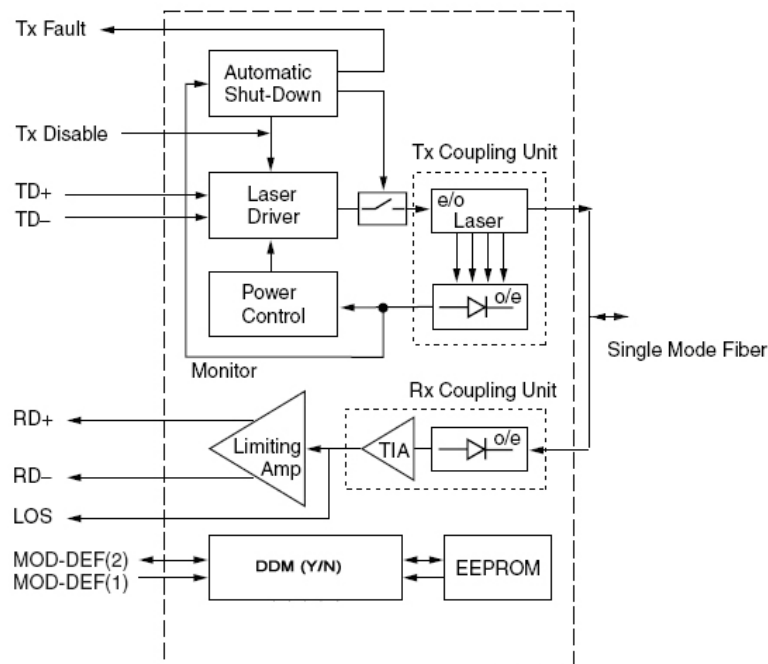

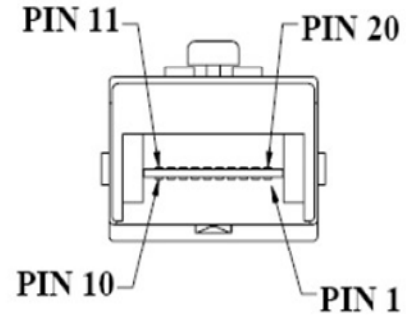
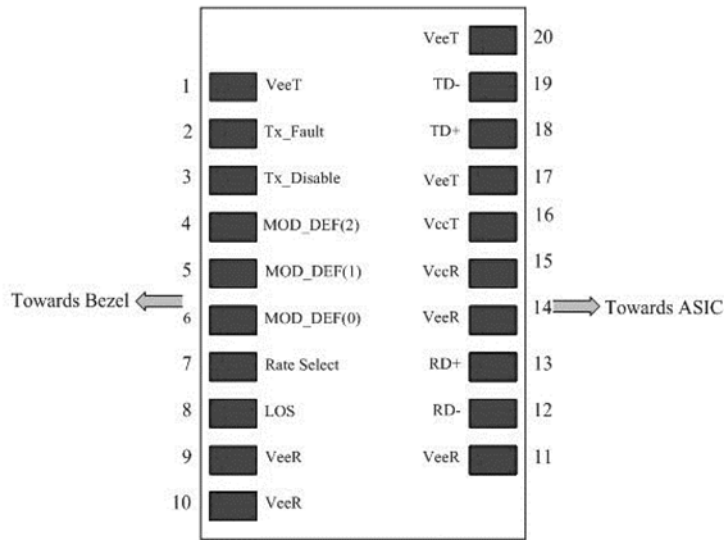
**SFP Transceiver Electrical Pad Layout**

**Pin Function Definitions**

Pin Num.	Name	FUNCTION	Plug Seq.	Notes
1	VeeT	Transmitter Ground	1	5)
2	TX Fault	Transmitter Fault Indication	3	1)
3	TX Disable	Transmitter Disable	3	2), Module disables on high or open
4	MOD-DEF2	Module Definition 2	3	3), Data line for Serial ID.
5	MOD-DEF1	Module Definition 1	3	3), Clock line for Serial ID.
6	MOD-DEF0	Module Definition 0	3	3), Grounded within the module.
7	Rate Select	Not Connect	3	Function not available
8	LOS	Loss of Signal	3	4)
9	VeeR	Receiver Ground	1	5)
10	VeeR	Receiver Ground	1	5)
11	VeeR	Receiver Ground	1	5)
12	RD-	Inv. Received Data Out	3	6)
13	RD+	Received Data Out	3	7)
14	VeeR	Receiver Ground	1	5)
15	VccR	Receiver Power	2	3.3 ± 5%, 7)
16	VccT	Transmitter Power	2	3.3 ± 5%, 7)
17	VeeT	Transmitter Ground	1	5)
18	TD+	Transmit Data In	3	8)
19	TD-	Inv. Transmit Data In	3	8)
20	VeeT	Transmitter Ground	1	5)

**Notes:**

- 1) TX Fault is an open collector/drain output, which should be pulled up with a 4.7K – 10K $\Omega$  resistor on the host board. Pull up voltage between 2.0V and VccT, R+0.3V. When high, output indicates a laser fault of some kind. Low indicates normal operation. In the low state, the output will be pulled to < 0.8V.
- 2) TX disable is an input that is used to shut down the transmitter optical output. It is pulled up within the module with a 4.7 – 10 K  $\Omega$  resistor. Its states are:  
Low (0 – 0.8V): Transmitter on  
(>0.8, < 2.0V): Undefined  
High (2.0 – 3.465V): Transmitter Disabled  
Open: Transmitter Disabled
- 3) Mod-Def 0,1,2. These are the module definition pins. They should be pulled up with a 4.7K – 10K $\Omega$  resistor on the host board. The pull-up voltage shall be VccT or VccR (see Section IV for further details). Mod-Def 0 is grounded by the module to indicate that the module is present Mod-Def 1 is the clock line of two wire serial interface for serial ID Mod-Def 2 is the data line of two wire serial interface for serial ID
- 4) LOS (Loss of Signal) is an open collector/drain output, which should be pulled up with a 4.7K – 10K $\Omega$  resistor. Pull up voltage between 2.0V and VccT, R+0.3V. When high, this output indicates the received optical power is below the worst-case receiver sensitivity (as defined by the standard in use). Low indicates normal operation. In the low state, the output will be pulled to <0.8V.
- 5) VeeR and VeeT may be internally connected within the SFP module.
- 6) RD-/+ : These are the differential receiver outputs. They are AC coupled 100 $\Omega$  differential lines which should be terminated with 100 $\Omega$  (differential) at the user SERDES. The AC coupling is done inside the module and is thus not required on the host board. The voltage swing on these lines will be between 370 and 2000 mV differential (185 –1000 mV single ended) when properly terminated.
- 7) VccR and VccT are the receiver and transmitter power supplies. They are defined as 3.3V  $\pm$ 5% at the SFP connector pin. Maximum supply current is 300mA. Recommended host board power supply filtering is shown below. Inductors with DC resistance of less than 1 ohm should be used in order to maintain the required voltage at the SFP input pin with 3.3V supply voltage. When the recommended supply-filtering network is used, hot plugging of the SFP transceiver module will result in an inrush current of no more than 30mA greater than the steady state value. VccR and VccT may be internally connected within the SFP transceiver module.
- 8) TD-/+ : These are the differential transmitter inputs. They are AC-coupled, differential lines with 100 $\Omega$  differential termination inside the module. The AC coupling is done inside the module and is thus not required on the host board. The inputs will accept differential swings of 500 – 2400 mV (250 – 1200mV single-ended), though it is recommended that values between 500 and 1200 mV differential (250 – 600mV single-ended) be used for best EMI performance.

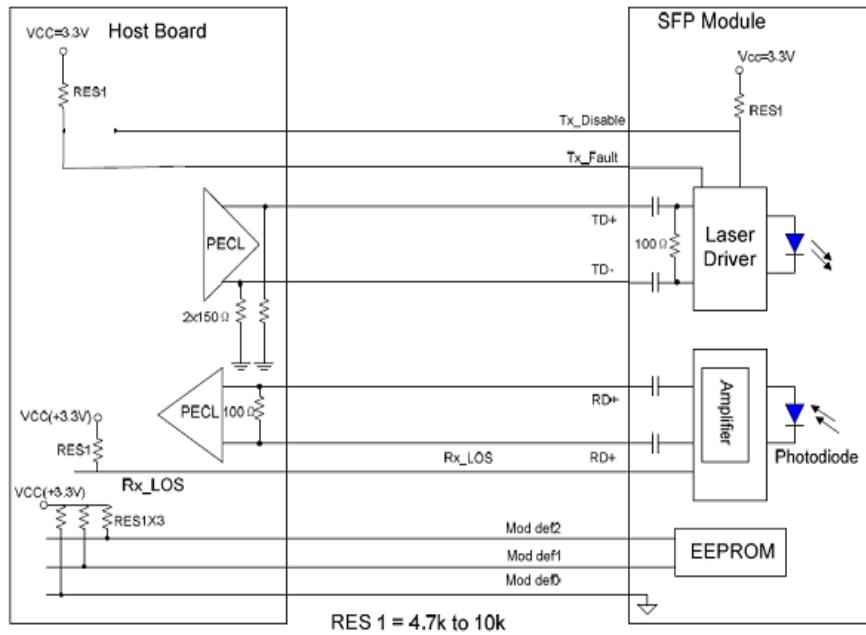
Recommend Circuit Schematic



Mechanical Specifications

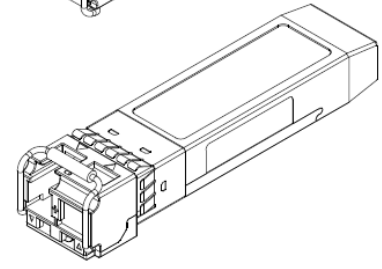
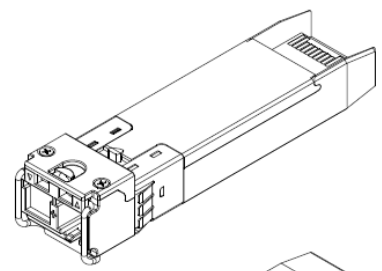
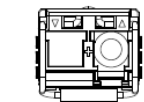
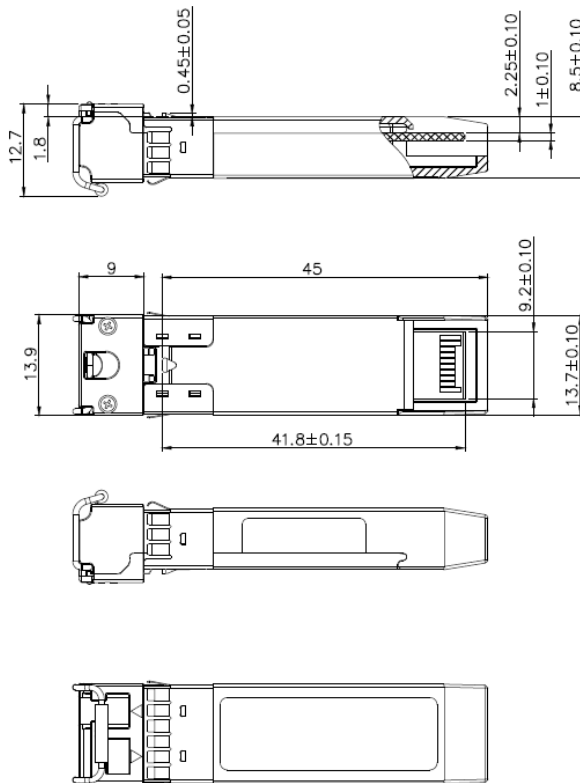

Unremarked tolerances ±0.2mm

LC

\*This 2D drawing only for reference, please check with Data Controls before ordering.



## Laser Emission

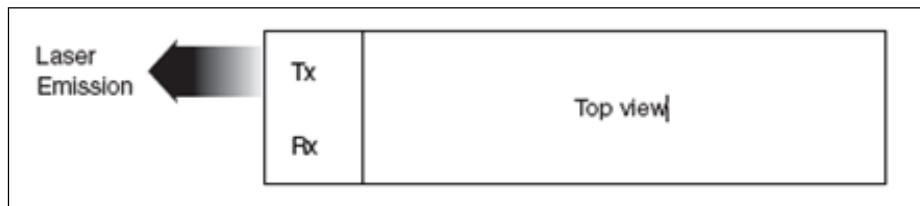

## Obtaining Document

You can visit our website:

<https://www.dci.jp>

Or contact Data Controls Inc. Listed at the end of the documentation to get the latest documents.

## Contact:

E-mail: [sales@dci.jp](mailto:sales@dci.jp)

<https://www.dci.jp>