

DGxx-SFP-LC.S160 Series

SFP Single-Mode for DWDM Application
Duplex SFP Transceiver
Digital Diagnostic Function
RoHS6 Compliant



Features

- ◆ Operating Data Rate up to 1.25Gbps
- ◆ Available in all C-Band Wavelengths on the 100GHz DWDM ITU Grid
- ◆ Single 3.3V Power Supply and TTL Logic Interface
- ◆ Hot-Pluggable SFP Footprint Duplex LC Connector Interface
- ◆ Compliant with Class 1 FDA and IEC60825-1 Laser Safety
- ◆ Compliant with SFP MSA
- ◆ Compliant with SFF-8472
- ◆ Operating Case Temperature:
Standard: 0°C to 70°C

Applications

- ◆ Amplified DWDM networks
- ◆ Ring topologies with fixed and reconfigurable OADMs
- ◆ Fast Ethernet, Giga Ethernet
- ◆ Fiber Channel
- ◆ CPRI rate: 1.229 Gb/s

Ordering Information

Part No.	Data Rate	Laser	Power budget*(note2)	Interface	Temperature
DGxx-SFP-LC.S160*(note1)	1.25Gbps	DWDM EML	37dB	LC	Standard

*The product image only for reference purpose.

Note1: XX refers to DWDM Wavelength range as ITU-T specified, please refer the following table for detailed center wavelength information.

Note2: The power budget which is guaranteed.

XX- Channel refers to the following table:

Channel (XX)	Part NO.	Frequency (THz)	Center Wavelength (nm)
17	DG17-SFP-LC.S160	191.7	1563.86
18	DG18-SFP-LC.S160	191.8	1563.05
19	DG19-SFP-LC.S160	191.9	1562.23
20	DG20-SFP-LC.S160	192.0	1561.42
21	DG21-SFP-LC.S160	192.1	1560.61
22	DG22-SFP-LC.S160	192.2	1559.79

23	DG23-SFP-LC.S160	192.3	1558.98
24	DG24-SFP-LC.S160	192.4	1558.17
25	DG25-SFP-LC.S160	192.5	1557.36
26	DG26-SFP-LC.S160	192.6	1556.55
27	DG27-SFP-LC.S160	192.7	1555.75
28	DG28-SFP-LC.S160	192.8	1554.94
29	DG29-SFP-LC.S160	192.9	1554.13
30	DG30-SFP-LC.S160	193.0	1553.33
31	DG31-SFP-LC.S160	193.1	1552.52
32	DG32-SFP-LC.S160	193.2	1551.72
33	DG33-SFP-LC.S160	193.3	1550.92
34	DG34-SFP-LC.S160	193.4	1550.12
35	DG35-SFP-LC.S160	193.5	1549.32
36	DG36-SFP-LC.S160	193.6	1548.51
37	DG37-SFP-LC.S160	193.7	1547.72
38	DG38-SFP-LC.S160	193.8	1546.92
39	DG39-SFP-LC.S160	193.9	1546.12
40	DG40-SFP-LC.S160	194.0	1545.32
41	DG41-SFP-LC.S160	194.1	1544.53
42	DG42-SFP-LC.S160	194.2	1543.73
43	DG43-SFP-LC.S160	194.3	1542.94
44	DG44-SFP-LC.S160	194.4	1542.14
45	DG45-SFP-LC.S160	194.5	1541.35
46	DG46-SFP-LC.S160	194.6	1540.56
47	DG47-SFP-LC.S160	194.7	1539.77
48	DG48-SFP-LC.S160	194.8	1538.98
49	DG49-SFP-LC.S160	194.9	1538.19
50	DG50-SFP-LC.S160	195.0	1537.40
51	DG51-SFP-LC.S160	195.1	1536.61
52	DG52-SFP-LC.S160	195.2	1535.82
53	DG53-SFP-LC.S160	195.3	1535.04
54	DG54-SFP-LC.S160	195.4	1534.25
55	DG55-SFP-LC.S160	195.5	1533.47
56	DG56-SFP-LC.S160	195.6	1532.68
57	DG57-SFP-LC.S160	195.7	1531.90
58	DG58-SFP-LC.S160	195.8	1531.12
59	DG59-SFP-LC.S160	195.9	1530.33
60	DG60-SFP-LC.S160	196.0	1529.55

Regulatory Compliance*^{Note3}

Product Certificate	Certificate Number	Applicable Standard
TUV	R50135086	EN 60950-1:2006+A11+A1+A12+A2
		EN 60825-1:2014
		EN 60825-2:2004+A1+A2
UL	E317337	UL 60950-1
		CSA C22.2 No. 60950-1-07
EMC CE	AE 50285865 0001	EN 55022:2010
		EN 55024:2010
FCC	WTF14F0514417E	47 CFR PART 15 OCT., 2013
FDA	/	CDRH 1040.10
ROHS	/	2011/65/EU

Note3: The above certificate number updated to June 2014, because some certificate will be updated every year, such as FDA and ROHS. For the latest certification information, please check with Data controls Inc.

Product Description

The DGxx-SFP-LC.S160 series single mode transceiver is small form factor pluggable module for duplex optical data communications. This module is designed for single mode fiber and operates at a nominal DWDM wavelength from 1528.77nm to 1565.50nm as specified by the ITU-T. It is designed to deploy in the DWDM networking equipment in metropolitan access and core networks.

It is with the SFP 20-pin connector to allow hot plug capability. The transmitter section uses a DWDM multiple quantum well EML laser and is a class 1 laser compliant according to International Safety Standard IEC-60825.

The DGxx-SFP-LC.S160 series are designed to be compliant with SFF-8472 Multi-Source Agreement (MSA).

Absolute Maximum Ratings

Parameter	Symbol	Min.	Max.	Unit
Storage Temperature	T _s	-40	+85	°C
Supply Voltage	V _{cc}	-0.5	3.6	V
Operating Relative Humidity		-	95	%

*Exceeding any one of these values may destroy the device permanently.

Recommended Operating Conditions

Parameter	Symbol	Min.	Typical	Max.	Unit
Operating Case Temperature	T _c	0	-	+70	°C
Power Supply Voltage	V _{cc}	3.15	3.3	3.45	V
Power Supply Current	I _{cc}	-	-	450	Ma

Date Rate				1.25G	bps
-----------	--	--	--	-------	-----

Performance Specifications – Electrical

Parameter	Symbol	Min.	Typ.	Max	Unit	Notes
Transmitter						
LVPECL Inputs(Differential)	Vin	400		2000	mVpp	AC coupled inputs*(note4)
Input Impedance (Differential)	Zin	85	100	115	ohm	Rin > 100 kohm @ DC
TX_Dis	Disable	2		Vcc	V	
	Enable	0		0.8		
TX_FAULT	Fault	2		Vcc	V	
	Normal	0		0.8		
Receiver						
LVPECL Outputs (Differential)	Vout	370		2000	mVpp	AC coupled outputs*(note4)
Output Impedance (Differential)	Zout	85	100	115	ohm	
RX_LOS	LOS	2		Vcc	V	
	Normal	0		0.8	V	
MOD_DEF (0:2)	VoH	2.5			V	
	VoL	0		0.8	V	

Performance Specifications – Optical

(DWDM EML and APD/TIA, 37Db Power Budget at Least)

Parameter	Symbol	Min.	Typical	Max.	Unit
Data Rate			1.25G		bps
Transmitter					
Center Wavelength	λ	1528		1566	nm
Spectral Width (-20Db)	$\Delta\lambda$			0.3	nm
Side Mode Suppression Ratio	SMSR	30			Db
Channel Spacing	Δf		100		GHz
Deviation From Central Frequency@EOL		-12		12	GHz
Average Output Power*(note5)	Pout	2		5	dBm
Average Launch Power (Tx: OFF)	Poff			-45	dBm
Extinction Ratio*(note6)	ER	8.2			Db
Rise/Fall Time(20%~80%)	tr/tf			260	ps
Output Optical Eye*(note6)	Compatible with IEEE 802.3*(note8)				
TX_Disable Assert Time	t_off			10	us
Pout@TX Disable Asserted	Pout			-45	dBm
Optical Signal Noise Ratio @ 0.1nm	OSNR		40		Db
Relative Intensity Noise	RIN			-135	Db/Hz

Dispersion Tolerance	DT		2800		ps/nm
Receiver					
Center Wavelength	λ	1528		1566	nm
Receiver Sensitivity*(note7)	Pmin			-35	dBm
Receiver Overload	Pmax	-10			dBm
LOS De-Assert	LOSD			-36	dBm
LOS Assert	LOSA	-45			dBm
LOS Hysteresis*(note9)		0.5			Db

Note4: LVPECL logic, internally AC coupled.

Note5: Output is coupled into a 9/125 μ m single-mode fiber.

Note6: Filtered, measured with a PRBS 2⁷-1 test pattern @1.25Gbps

Note7: Minimum average optical power measured at BER less than 1E-12, with a 2⁷-1 PRBS and ER=9Db.

Note8: Eye Pattern Mask

Note9: LOS Hysteresis

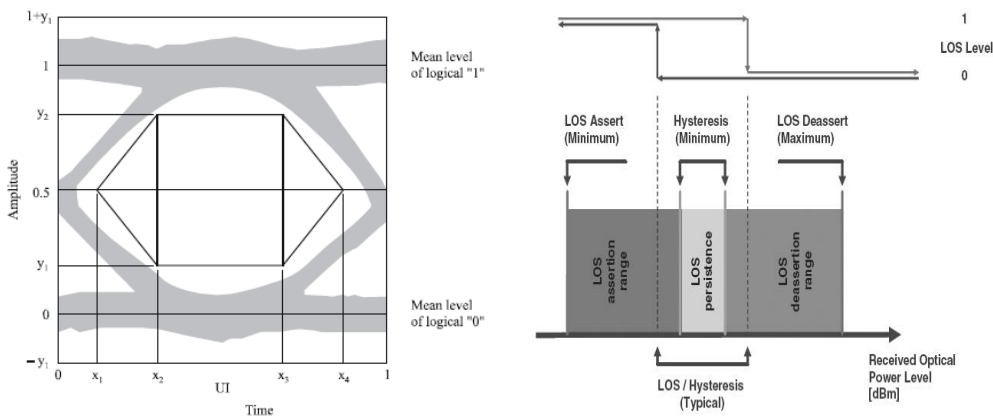

Functional Description of Transceiver

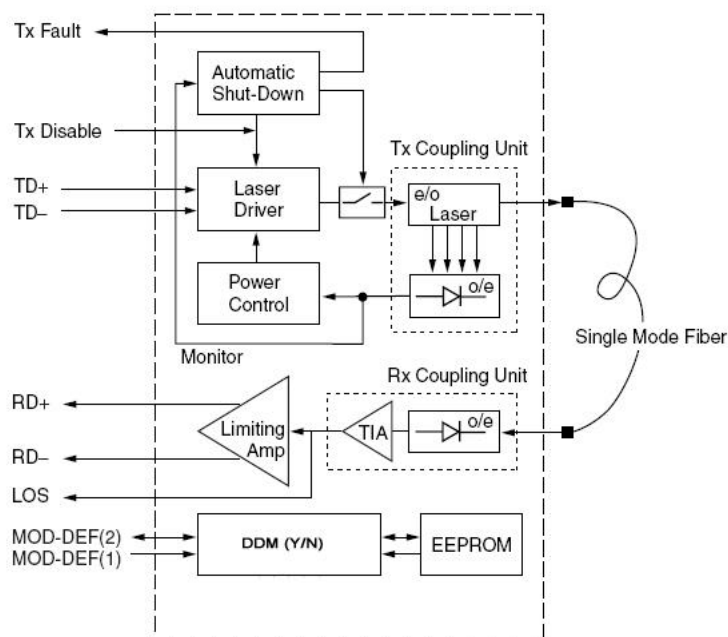

SFP Transceiver Electrical Pad Layout

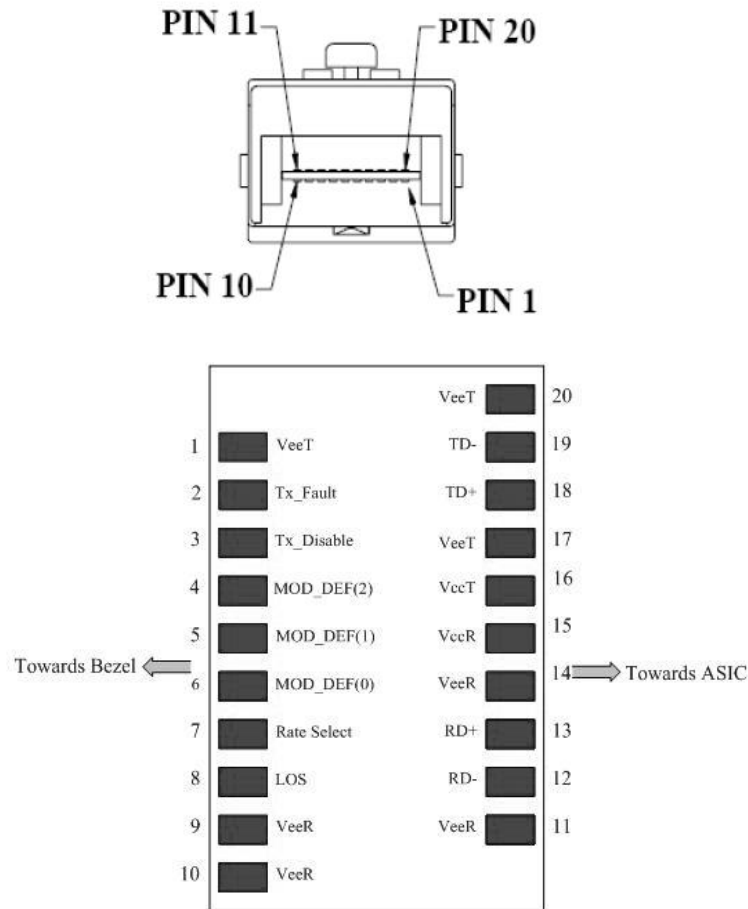

Pin Function Definitions

Pin Num.	Name	Function Description
1	VeeT	Transmitter Ground
2	TX Fault	Transmitter Fault Indication, open collector/drain output
3	TX Disable	Transmitter Disable
4	MOD-DEF2	Module Definition 2, Data line for Serial ID.
5	MOD-DEF1	Module Definition 1, Clock line for Serial ID.
6	MOD-DEF0	Module Definition 0, Grounded within the module.
7	Rate Select	Not Connect, Function not available
8	LOS	Loss of Signal, open collector/drain output
9	VeeR	Receiver Ground
10	VeeR	Receiver Ground
11	VeeR	Receiver Ground
12	RD-	Inv. Received Data Out
13	RD+	Received Data Out
14	VeeR	Receiver Ground
15	VccR	Receiver Power, 3.3 ± 5%
16	VccT	Transmitter Power, 3.3 ± 5%

17	VeeT	Transmitter Ground
18	TD+	Transmit Data In
19	TD-	Inv. Transmit Data In
20	VeeT	Transmitter Ground

EEPROM

The serial interface uses the 2-wire serial CMOS EEPROM protocol defined for the ATMEL AT24C02/04 family of components. When the serial protocol is activated, the host generates the serial clock signal (SCL). The positive edge clocks data into those segments of the EEPROM that are not write protected within the SFP transceiver. The negative edge clocks data from the SFP transceiver. The serial data signal (SDA) is bi-directional for serial data transfer. The host uses SDA in conjunction with SCL to mark the start and end of serial protocol activation. The memories are organized as a series of 8-bit data words that can be addressed individually or sequentially.

The Module provides diagnostic information about the present operating conditions. The transceiver generates this diagnostic data by digitization of internal analog signals. Calibration and alarm/warning threshold data is written during device manufacture. Received power monitoring, transmitted power monitoring, bias current monitoring, supply voltage monitoring and temperature monitoring all are implemented. If the module is defined as external calibrated, the diagnostic data are raw A/D values and must be converted to real world units using calibration constants stored in EEPROM locations 56 – 95 at wire serial bus address A2H. The digital diagnostic memory map specific data field define as following .For detail EEPROM information, please refer to the related document of SFF 8472 Rev 9.3.

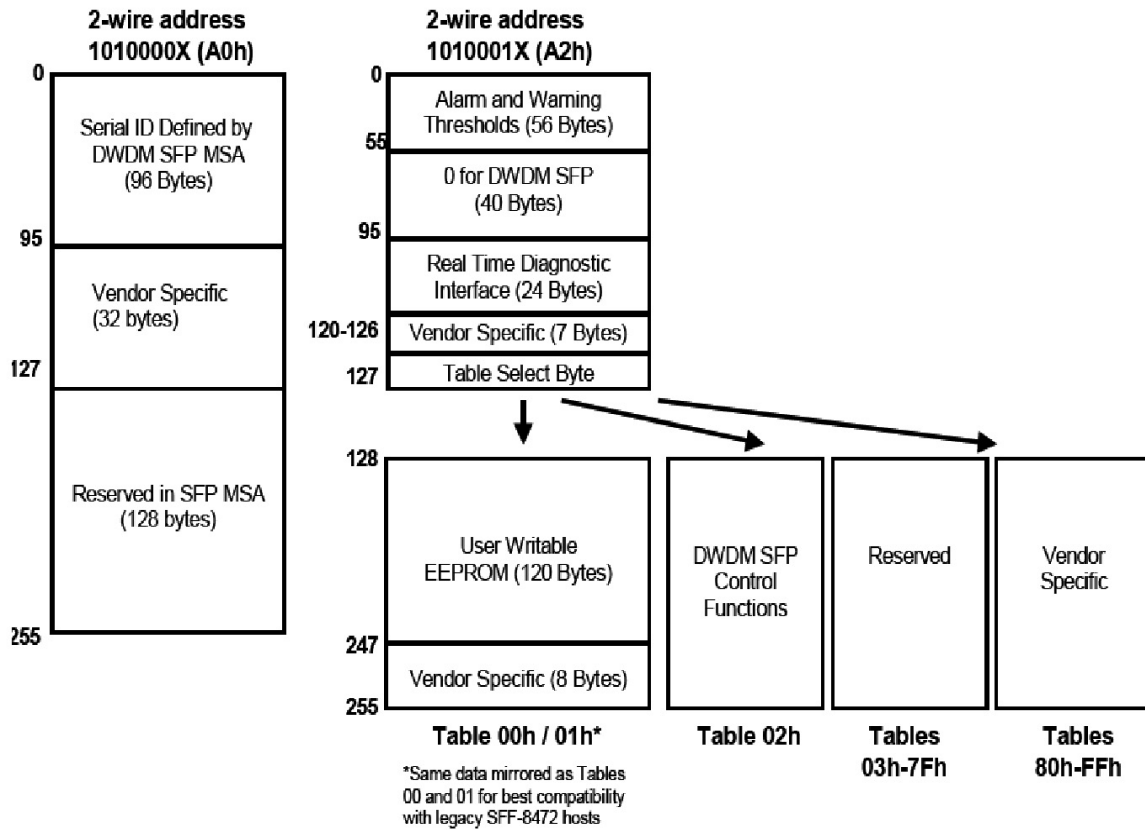

EEPROM Serial ID Memory Contents

Accessing Serial ID Memory uses the 2 wire address 1010000X(A0H). Memory Contents of Serial ID are shown in Table 1.

Table 1 Serial ID Memory Contents

Addr.	Size(bytes)	Name of field	Vaule(Hex)	Description
0	1	Identifier	0B	DWDM SFP
1	1	Ext. Identifier	XX	
2	1	Connector	07	LC connector
3-10	8	Transceiver Codes	00	Reserved
			00	-
			00	-
			XX	
			XX	
			XX	
			01	Single mode
			XX	
11	1	Encoding	XX	
12	1	BR, Nominal	0D	1.25Gbps
13	1	Reserved	00	-
14	1	Length (9µm)km	XX	
15	1	Length(9µm)100m	FF	

16	1	Length (50µm) 10m	00	
17	1	Length(62.5µm)10m	00	
18	1	Length (Copper)	00	Not compliant
19	1	Reserved	00	
20~35	16	Vendor Name	Data Controls	Vendor name
36	1	Implemented Optional DWDM Features	00	-
37-39	3	Vendor OUI	68F125	-
40-55	16	Vendor PN	DGxxSFPLCS160	PN
56-59	4	Vendor Rev	XX XX XX XX ^(note10)	
60-62	3	Wavelength	XX	Laser Wavelength
63	1	CC-BASE	XX	CC for Base ID fields implemented (addresses 0 to62)
64~65	2	Options	00	Reserved
			1A	1.TX_DISABLE is implemented and disables the serial output; 2.TX_FAULT signal implemented; 3.Loss of Signal implemented
66	1	BR, max	00	-
67	1	BR, max	00	-
68~83	16	Vendor SN	XX	Serial number of Transceiver (ASCII)
84~89	6	Date code	XX	The vendor's date code (ASCII)
90~91	2	Vendor specific lot code	XX XX	-
92	1	Diagnostic Monitoring Type	XX	1. Digital diagnostic monitoring implemented 2.Internally/Externally Calibrated; 3.Received power measurement type is Average Power
93	1	Enhanced Options	F0	1.Optional Alarm/warning flags implemented for all monitored quantities 2. Optional Soft TX_DISABLE control and

				monitoring implemented 3. Optional Soft TX_FAULT monitoring Implemented 4. Optional Soft RX_LOS monitoring Implemented
94	1	SFF-8472 Compliance	01	Includes functionality described in Rev 9.3 of SFF-8472.
95	1	CC_EXT	XX	CC for the Industrial ID Fields (addresses 64 to 94) implemented.
96~127	32	Vendor Specific	XX	Read only memory
128-255	128	Reserved	Read only	

Note10: The "XX" byte should be filled in according to practical case. For more information, please refer to the related document of SFP Multi-Source Agreement (MSA).

Recommend Circuit Schematic

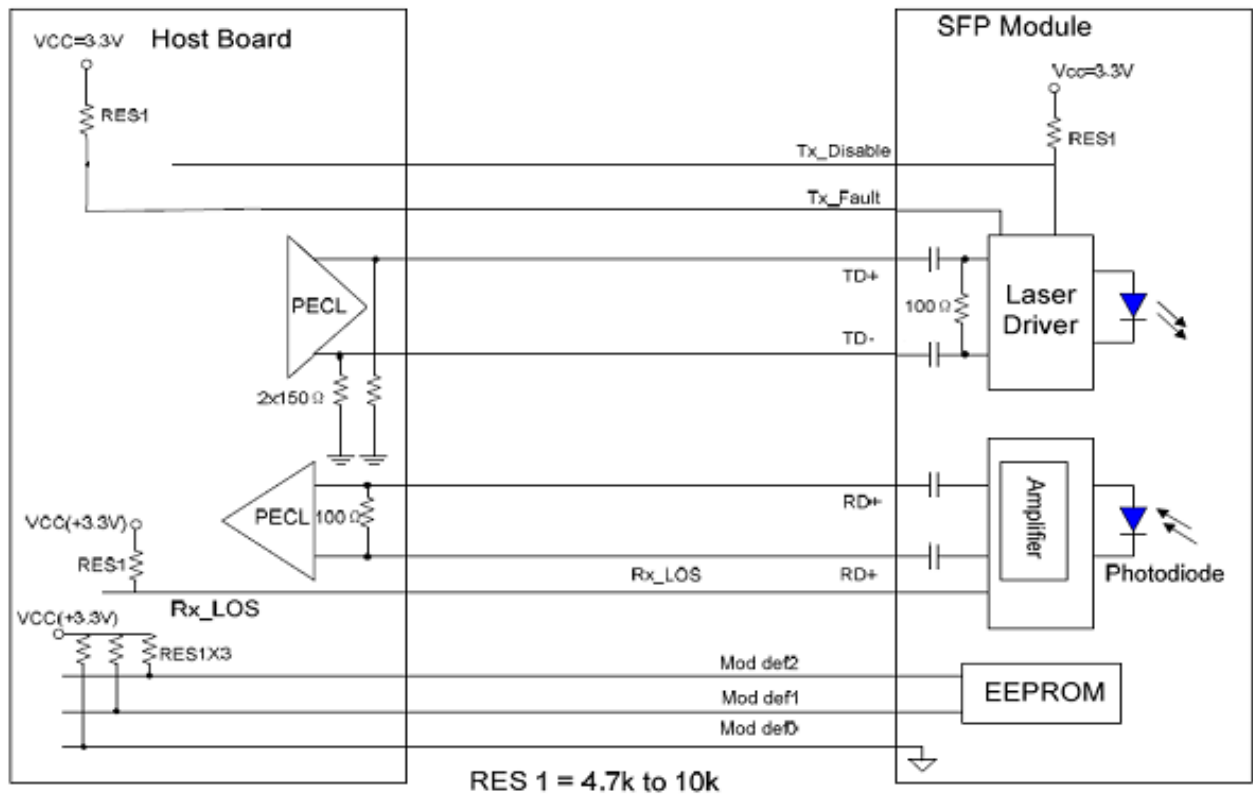

Mechanical Specifications

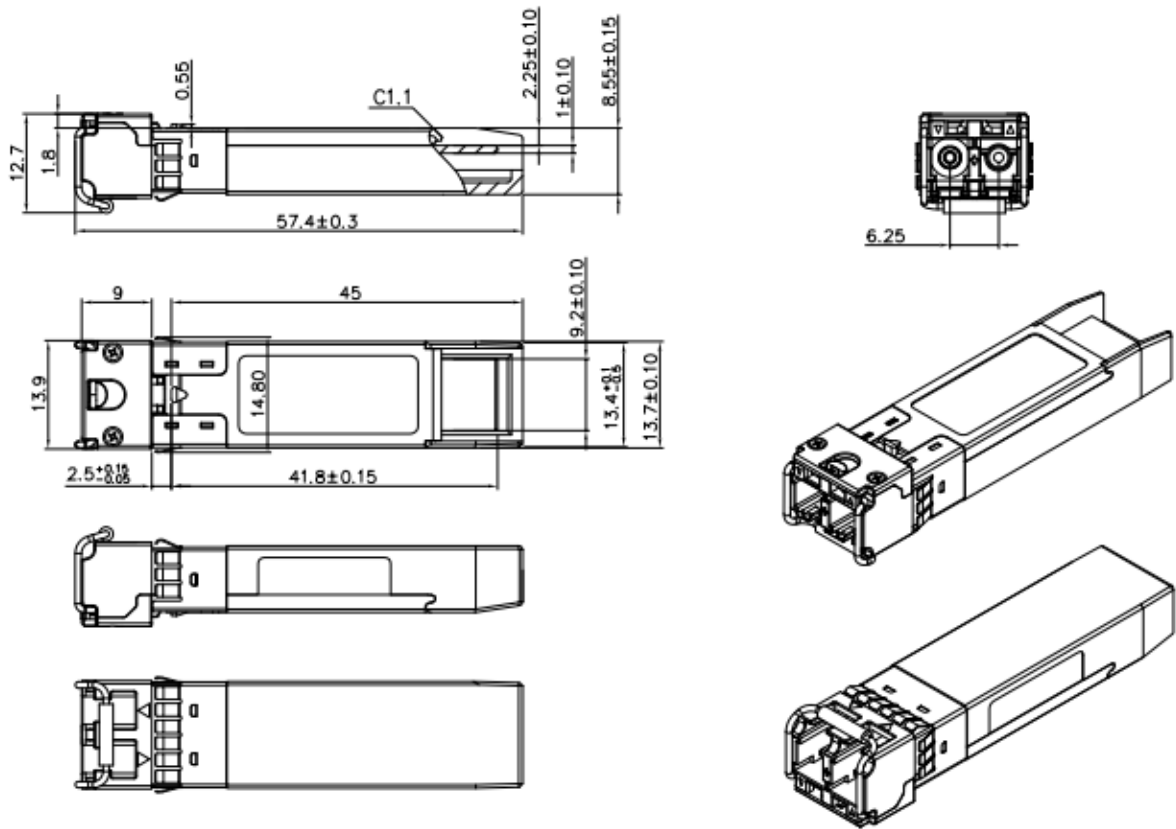

Unremarked tolerances $\pm 0.2\text{mm}$

*This 2D drawing only for reference, please check with Data Controls Inc before ordering.

Contact

Data Controls Inc.

sales@dcj.jp www.dci.jp