

DJxx-XFP-LC.S40

XFP Single-Mode for 10GbE/10GFC/SDH/SONET
Duplex XFP Transceiver
RoHS6 Compliant

Features

- ◆ Supports 9.95Gb/s to 11.1Gb/s bit Rates
- ◆ Hot-Pluggable XFP Footprint
- ◆ 14dB Power Budget
- ◆ Temperature-Stabilized DWDM Rated EML Transmitter
- ◆ 100GHz ITU Grid, C Band
- ◆ Duplex LC Connector
- ◆ Built-in Digital Diagnostic Functions
- ◆ Support Line Side Loopback
- ◆ Support XFI Loopback
- ◆ Auxiliary 1 Monitoring Laser Temperature
- ◆ Auxiliary 2 Monitoring 5V Supply
- ◆ Operating Case Temperature:
Standard: 0°C to 70°C



Applications

- ◆ 10GBASE-ER/EW Ethernet
- ◆ 1200-SM-LL-L 10G Fiber Channel
- ◆ SONET OC-192 IR-2
- ◆ SDH STM S-64.2b
- ◆ SONET OC-192 IR-3
- ◆ SDH STM S-64.3b
- ◆ ITU-T G.709

Ordering Information

Part No.	Data Rate	Laser	Power Budget	Temp.	Optical Interface
DJxx-XFP-LC.S40	10Gbps	EML EA	14dB	Standard	LC

XX- Channel refers to the following table:

Channel	Part NO.	Frequency (THz)	Center Wavelength (nm)
17*	DJ17-XFP-LC.S40	191.7	1563.86
18*	DJ18-XFP-LC.S40	191.8	1563.05
19*	DJ19-XFP-LC.S40	191.9	1562.23
20*	DJ20-XFP-LC.S40	192.0	1561.42
21	DJ21-XFP-LC.S40	192.1	1560.61
22	DJ22-XFP-LC.S40	192.2	1559.79

23	DJ23-XFP-LC.S40	192.3	1558.98
24	DJ24-XFP-LC.S40	192.4	1558.17
25	DJ25-XFP-LC.S40	192.5	1557.36
26	DJ26-XFP-LC.S40	192.6	1556.55
27	DJ27-XFP-LC.S40	192.7	1555.75
28	DJ28-XFP-LC.S40	192.8	1554.94
29	DJ29-XFP-LC.S40	192.9	1554.13
30	DJ30-XFP-LC.S40	193.0	1553.33
31	DJ31-XFP-LC.S40	193.1	1552.52
32	DJ32-XFP-LC.S40	193.2	1551.72
33	DJ33-XFP-LC.S40	193.3	1550.92
34	DJ34-XFP-LC.S40	193.4	1550.12
35	DJ35-XFP-LC.S40	193.5	1549.32
36	DJ36-XFP-LC.S40	193.6	1548.51
37	DJ37-XFP-LC.S40	193.7	1547.72
38	DJ38-XFP-LC.S40	193.8	1546.92
39	DJ39-XFP-LC.S40	193.9	1546.12
40	DJ40-XFP-LC.S40	194.0	1545.32
41	DJ41-XFP-LC.S40	194.1	1544.53
42	DJ42-XFP-LC.S40	194.2	1543.73
43	DJ43-XFP-LC.S40	194.3	1542.94
44	DJ44-XFP-LC.S40	194.4	1542.14
45	DJ45-XFP-LC.S40	194.5	1541.35
46	DJ46-XFP-LC.S40	194.6	1540.56
47	DJ47-XFP-LC.S40	194.7	1539.77
48	DJ48-XFP-LC.S40	194.8	1538.98
49	DJ49-XFP-LC.S40	194.9	1538.19
50	DJ50-XFP-LC.S40	195.0	1537.40
51	DJ51-XFP-LC.S40	195.1	1536.61
52	DJ52-XFP-LC.S40	195.2	1535.82
53	DJ53-XFP-LC.S40	195.3	1535.04
54	DJ54-XFP-LC.S40	195.4	1534.25
55	DJ55-XFP-LC.S40	195.5	1533.47
56	DJ56-XFP-LC.S40	195.6	1532.68
57	DJ57-XFP-LC.S40	195.7	1531.90
58	DJ58-XFP-LC.S40	195.8	1531.12
59	DJ59-XFP-LC.S40	195.9	1530.33
60*	DJ60-XFP-LC.S40	196.0	1529.55

*Note1: This channel is supported with limited availability; please contact DCI for further details.

Regulatory Compliance

Product Certificate	Certificate Number	Applicable Standard
TUV	R50135086	EN 60950-1:2006+A11+A1+A12
		EN 60825-1:2007
		EN 60825-2:2004+A1+A2
UL	E317337	UL 60950-1
		CSA C22.2 No. 60950-1-07
EMC CE	AE 50135430 0001	EN 55022:2006
		EN 55024:1998+A1+A2
CB	JPTUV-024038-M1	IEC 60825-2
		IEC 60950-1
FCC	WTF13F0503735E	47 CFR PART 15 OCT., 2010
	WTF13F0503732E	47 CFR PART 15 OCT., 2010
FDA	1230816-000	CDRH 1040.10
ROHS	RLSZF00163462	2011/65/EU

Absolute Maximum Ratings

Parameter	Symbol	Min	Typ.	Max	Unit
Maximum Supply Voltage 1	Vcc3	-0.5		4.0	V
Maximum Supply Voltage 2	Vcc5	-0.3		6.0	V
Storage Temperature	T _s	-40		85	°C

Recommend Operating Condition

Parameter	Symbol	Min	Typ.	Max	Units	Ref.
Supply Voltage 1	Vcc3	3.13	3.3	3.45	V	
Supply Voltage 2	Vcc5	4.75	5	5.25	V	
Case Operating Temperature	T _c	0		70	°C	

Electrical Characteristics

Parameter	Symbol	Min	Typ.	Max	Unit	Note	
Main Supply Voltage	Vcc5	4.75		5.25	V		
Supply Voltage #2	Vcc3	3.13		3.45	V		
Supply Current – Vcc5 supply	Icc5			500	mA		
Supply Current – Vcc3 supply	Icc3			750	mA		
Transmitter							
Input Differential Impedance	Rin		100		Ω	1	
Differential Data Input Swing	Vin, pp	120		820	mV		
Transmit Disable Voltage	V _D	2.0		Vcc	V		
Transmit Enable Voltage	V _{EN}	GND		GND+0.8	V		
Transmit Disable Assert Time				10	μs		
Receiver							
Differential Data Output Swing	Vout,pp	340	650	850	mV		
Data Output Rise Time	Tr			38	ps	2	
Data Output Fall Time	Tf			38	ps	2	
LOS Fault	V _{LOS Fault}	Vcc – 0.5		V _{CCHOST}	V	3	
LOS Normal	V _{LOS Normal}	GND		GND+0.5	V	3	
Power Supply Noise Rejection	PSNR	Compliant to Section 2.7.1 of XFP MSA					

Notes:

1. Internal AC coupling.
2. 20% – 80%
3. Loss Of Signal is open collector to be pulled up with a 4.7k – 10kohm resistor to 3.15 – 3.6V. Logic 0 indicates normal operation; logic 1 indicates no signal detected.

Optical Characteristics

Please note that the transmitter becomes operational within 60 seconds of power-up. This is due to the time required for the EML to reach its optimum operating temperature.

Parameter	Symbol	Min	Typ	Max	Unit	Ref.
Transmitter						
Output Opt. Pwr: 9/125 SMF	Pout	-1		+4	dBm	
Center Wavelength Spacing			100		GHz	
			0.8		nm	
Optical Wavelength-EOL	λ _c	X-100	X	X+100	pm	
Transmitter Center Wavelength –BOL	λ _c	X-40	X	X+40	pm	
Optical Extinction Ratio	ER	8.2			dB	
Transmitter and Dispersion Penalty	TDP			2	dB	
Side Mode Suppression Ratio	SMSR	30			dB	
TX Jitter Generation	TXj			0.1	UI	

(peak-to-peak)						
TX Jitter Generation (RMS)	TX _{JRMS}			0.01	UI	
Receiver						
Receiver Sensitivity @ 10.7Gb/s	P _{min}			-15	dBm	
Maximum Input Power	P _{max}	+0.5			dBm	
Optical Center Wavelength	λ _c	1270		1600	nm	
Path Penalty				2	dB	
Receiver Reflectance	R _{rx}			-27	dB	
LOS De-Assert	LOSD			-17	dBm	
LOS Assert	LOSA	-29			dBm	
LOS Hysteresis		1			dB	

Pin Descriptions

Pin	Logic	Symbol	Name/Description	Ref.
1		GND	Module Ground	1
2		VEE5	Optional -5.2 Power Supply – Not required	
3	LVTTL-I	Mod-Desel	Module De-select; When held low allows the module to respond to 2-wire serial interface commands	
4	LVTTL-O	Interrupt	Interrupt (bar); Indicates presence of an important condition which can be read over the serial 2-wire interface	2
5	LVTTL-I	TX_DIS	Transmitter Disable; Transmitter laser source turned off	
6		VCC5	+5 Power Supply	
7		GND	Module Ground	1
8		VCC3	+3.3V Power Supply	
9		VCC3	+3.3V Power Supply	
10	LVTTL-I	SCL	Serial 2-wire interface clock line	2
11	LVTTL-I/O	SDA	Serial 2-wire interface data line	2
12	LVTTL-O	Mod_Abs	Module Absent; Indicates module is not present. Grounded in the module.	2
13	LVTTL-O	Mod_NR	Module Not Ready;	2
14	LVTTL-O	RX_LOS	Receiver Loss of Signal indicator	2
15		GND	Module Ground	1
16		GND	Module Ground	1
17	CML-O	RD-	Receiver inverted data output	
18	CML-O	RD+	Receiver non-inverted data output	
19		GND	Module Ground	1
20		VCC2	+1.8V Power Supply – Not required	
21	LVTTL-I	P_Down/R	Power Down; When high, places the module in the low	

		ST	power stand-by mode and on the falling edge of P_Down initiates a module reset	
			Reset; The falling edge initiates a complete reset of the module including the 2-wire serial interface, equivalent to a power cycle.	
22		VCC2	+1.8V Power Supply – Not required	
23		GND	Module Ground	1
24	PECL-I	RefCLK+	Reference Clock non-inverted input, AC coupled on the host board – Not required	3
25	PECL-I	RefCLK-	Reference Clock inverted input, AC coupled on the host board – Not required	3
26		GND	Module Ground	1
27		GND	Module Ground	1
28	CML-I	TD-	Transmitter inverted data input	
29	CML-I	TD+	Transmitter non-inverted data input	
30		GND	Module Ground	1

Notes:

1. Module circuit ground is isolated from module chassis ground within the module.
2. Open collector; should be pulled up with 4.7k – 10k ohm on host board to a voltage between 3.15V and 3.6V.
3. A Reference Clock input is not required.

Digital Diagnostic Functions

DJxx-XFP-LC.S40 Small Form Factor 10Gbps (XFP) transceivers are compliant with the current XFP Multi-Source Agreement (MSA) Specification Rev 4.5.

As defined by the XFP MSA, our XFP transceivers provide digital diagnostic functions via a 2-wire serial interface, which allows real-time access to the following operating parameters:

- ◆ Transceiver temperature
- ◆ Laser temperature
- ◆ Laser bias current
- ◆ Transmitted optical power
- ◆ Received optical power
- ◆ Transceiver supply voltage

It also provides a sophisticated system of alarm and warning flags, which may be used to alert end-users when particular operating parameters are outside of a factory-set normal range.

The operating and diagnostics information is monitored and reported by a Digital Diagnostics Transceiver Controller inside the transceiver, which is accessed through the 2-wire serial interface. When the serial protocol is activated, the serial clock signal (SCL pin) is generated by the host. The positive edge clocks data into the XFP transceiver into those segments of its memory map that are not write-protected. The negative edge clocks data from the XFP transceiver. The serial data signal (SDA pin) is bi-directional for serial data transfer. The host uses SDA in conjunction with SCL to mark the start and end of serial protocol activation. The memories are organized as a series of 8-bit data words that can be addressed individually or sequentially. The 2-wire serial interface provides sequential or random access to the 8 bit parameters, addressed from 000h to the maximum address of the memory.

Table 1 Serial ID Memory Contents (Table 01h)

Addr.	Size (Bytes)	Name of Field	Hex	Description
128	1	Identifier	06	XFP
129	1	Ext. Identifier	90	power consumption < 3.5W, no Ref Colck required
130	1	Connector	07	LC Connector
131~138	8	Transceiver	22 20 00 00 00 20 00 00	Transmitter Code
139	1	Encoding	F0	64B/66B, 8B/10B,SONET Scrambled, NRZ
140	1	BR-Min	63	9.9Gbps
141	1	BR-Max	6F	11.1Gbps
142	1	Length (SMF)km	XX ^(note)	
143	1	Length (E-50µm)	00	
144	1	Length (50µm)	00	
145	1	Length(62.5µm)	00	
146	1	Length (Copper)	00	Not compliant
147	1	Device Tech	74	1550 EML, PIN detector
148~163	16	Vendor name	Data Controls	
164	1	CDR Support	F9	CDR supports 9.953G ~ 11.1G
165~167	3	Vendor OUI	68F125	
168~183	16	Vendor PN	DJxxXFPLCS40	
184~185	2	Vendor rev	XX XX XX XX ^(note)	
186~187	2	Wavelength Tolerance	XX XX ^(note)	Centre Wavelength
188~189	2	Wavelength Tolerance	00 14	+/- 0.1 nm
190	1	Max Case Temp	XX ^(note)	XX
191	1	CC_BASE	XX ^(note)	Check sum of Byte 128 –

				190
192~195	4	Power Supply	XX XX XX XX ^(note)	
196~211	16	Vendor SN	XX XX XX XX XX XX XX XX XX XX XX XX XX XX XX XX ^(note)	
212~219	8	Date Code	XX XX XX XX XX XX XX XX ^(note)	
220	1	Diagnostic Monitoring Type	08	No BER Support, Average Power
221	1	Enhanced Options	60	Optional Soft TX_DISABLE implemented, Optional Soft P_down implemented
222	1	Aux Monitoring	46	AUX1: Laser Temperature AUX2: 5V Power Supply
223	1	CC_EXT	XX ^(note)	
224~255	32	Vendor Specific	Reserved	Check sum for Extended ID Field.

NOTE: "XX" is referred to be variable.

Host board Connector Pinout

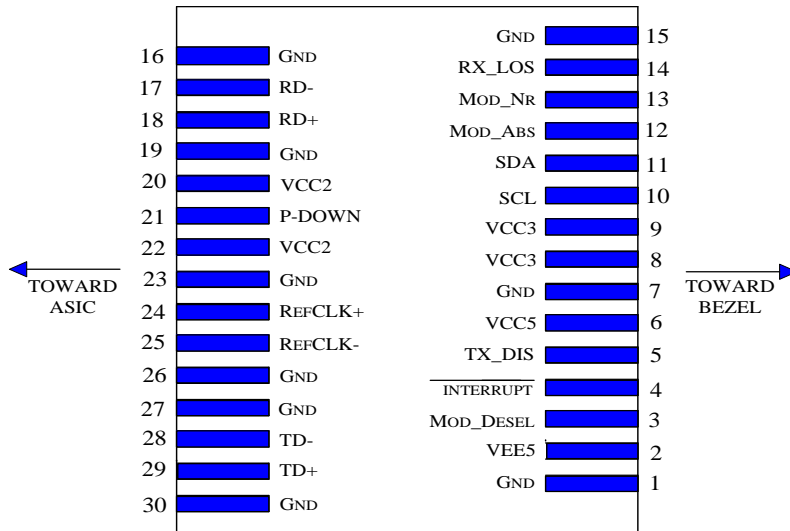

Diagram of Host Board Connector Block Pin Numbers and Name

General Specifications

Parameter	Symbol	Min	Typ.	Max	Units	Ref.
Bit Rate	BR	9.95		11.1	Gbps	1
Bit Error Ratio	BER			10 ⁻¹²		2

Notes:

1. SONET OC-192 IR-2, OC-192 IR-3, ITU-T G.709, 10GBASE-ER/EW with FEC, 10G Fiber Channel
2. Tested with a 2³¹ – 1 PRBS

Recommended Host Board Power Supply Circuit

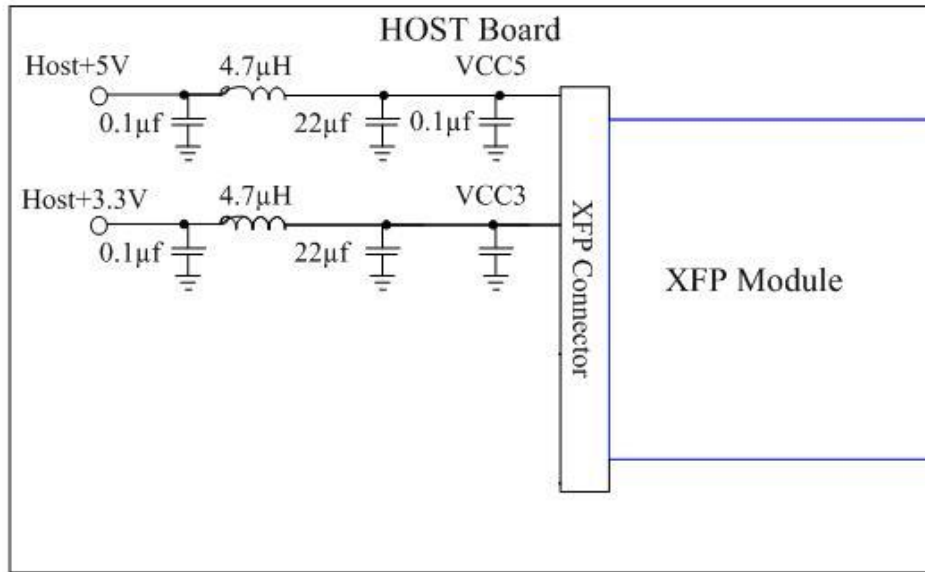

Recommended High-Speed Interface Circuit

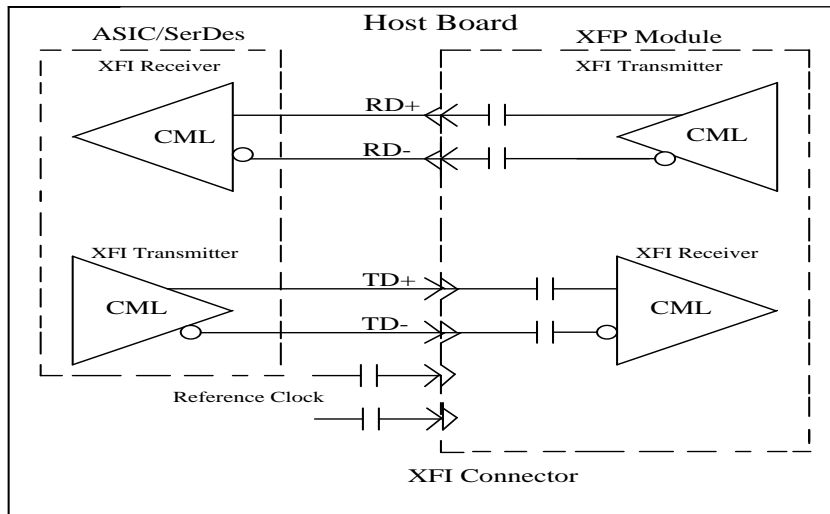

Mechanical Specifications

XFP transceivers are compliant with the dimensions defined by the XFP Multi-Sourcing Agreement (MSA).

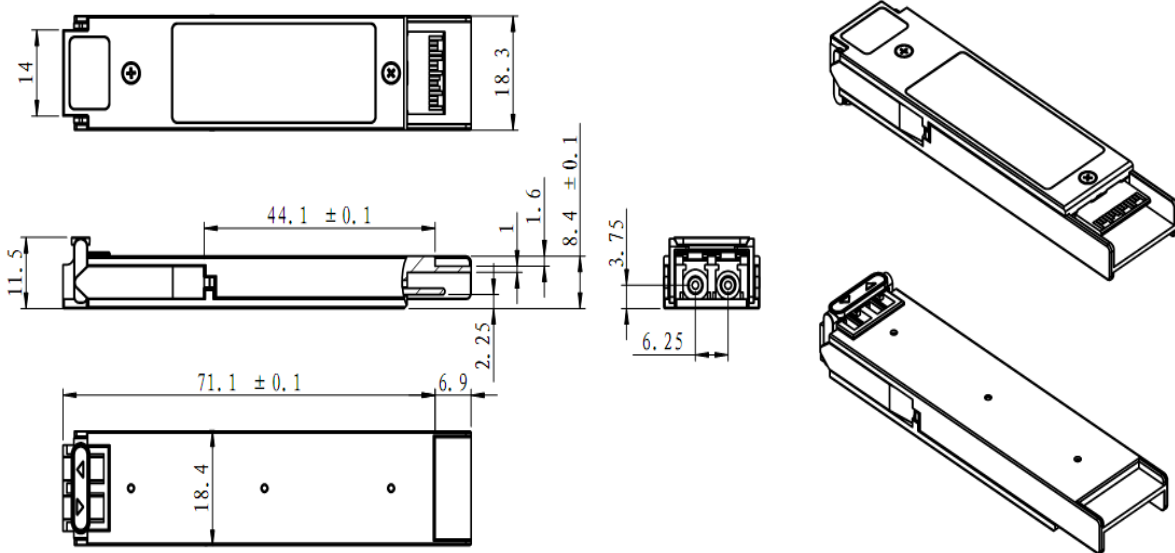

Eye Safety

This single-mode transceiver is a Class 1 laser product. It complies with IEC-60825 and FDA 21 CFR 1040.10 and 1040.11. The transceiver must be operated within the specified temperature and voltage limits. The optical ports of the module shall be terminated with an optical connector or with a dust plug.

Contact

Data Controls Inc.

sales@dcj.jp www.dci.jp