

DJxx-XFP-LC.S80

XFP DWDM Single-Mode for 10GbE/10GFC/SDH/SONET
Duplex XFP Transceiver
RoHS6 Compliant

Features

- ◆ Available in all C-Band Wavelength on the 100GHz ITU-T Grid
- ◆ Supports 9.95Gb/s to 11.1Gb/s Bit Rates
- ◆ Hot-pluggable XFP footprint
- ◆ Power Budget 24dB
- ◆ Temperature-Stabilized DWDM Rated EML Transmitter
- ◆ Duplex LC connector
- ◆ Built-in Digital Diagnostic Functions
- ◆ Support Line Side Loopback
- ◆ Support XFI Loopback
- ◆ Auxiliary 1 Monitoring Laser Temperature
- ◆ Auxiliary 2 Monitoring 5V Supply
- ◆ Temperature Range -5°C to 70°C



Applications

- ◆ 10GBASE-ZR/ZW
- ◆ 1200-SM-LL-L 10G Fiber Channel
- ◆ SONET OC-192
- ◆ SDH STM S-64
- ◆ P1L1-2D2
- ◆ ITU-T G.709

Ordering Information

Part No.	Data Rate	Laser	Fiber Type	Power Budget	Optical Interface
DJxx-XFP-LC.S80*	10G	EML EA	SMF	24dB	LC

Note1: X refers to page 2-DWDM Wavelength List

DWDM Wavelength List:

Channel	Part NO.	Frequency (THz)	Center Wavelength (nm)
17	DJ17-XFP-LC.S80	191.7	1563.86
18	DJ18-XFP-LC.S80	191.8	1563.05
19	DJ19-XFP-LC.S80	191.9	1562.23
20	DJ20-XFP-LC.S80	192.0	1561.42
21	DJ21-XFP-LC.S80	192.1	1560.61
22	DJ22-XFP-LC.S80	192.2	1559.79
23	DJ23-XFP-LC.S80	192.3	1558.98
24	DJ24-XFP-LC.S80	192.4	1558.17
25	DJ25-XFP-LC.S80	192.5	1557.36
26	DJ26-XFP-LC.S80	192.6	1556.55
27	DJ27-XFP-LC.S80	192.7	1555.75
28	DJ28-XFP-LC.S80	192.8	1554.94
29	DJ29-XFP-LC.S80	192.9	1554.13
30	DJ30-XFP-LC.S80	193.0	1553.33
31	DJ31-XFP-LC.S80	193.1	1552.52
32	DJ32-XFP-LC.S80	193.2	1551.72
33	DJ33-XFP-LC.S80	193.3	1550.92
34	DJ34-XFP-LC.S80	193.4	1550.12
35	DJ35-XFP-LC.S80	193.5	1549.32
36	DJ36-XFP-LC.S80	193.6	1548.51
37	DJ37-XFP-LC.S80	193.7	1547.72
38	DJ38-XFP-LC.S80	193.8	1546.92
39	DJ39-XFP-LC.S80	193.9	1546.12
40	DJ40-XFP-LC.S80	194.0	1545.32
41	DJ41-XFP-LC.S80	194.1	1544.53
42	DJ42-XFP-LC.S80	194.2	1543.73
43	DJ43-XFP-LC.S80	194.3	1542.94
44	DJ44-XFP-LC.S80	194.4	1542.14
45	DJ45-XFP-LC.S80	194.5	1541.35
46	DJ46-XFP-LC.S80	194.6	1540.56
47	DJ47-XFP-LC.S80	194.7	1539.77
48	DJ48-XFP-LC.S80	194.8	1538.98
49	DJ49-XFP-LC.S80	194.9	1538.19
50	DJ50-XFP-LC.S80	195.0	1537.40
51	DJ51-XFP-LC.S80	195.1	1536.61
52	DJ52-XFP-LC.S80	195.2	1535.82
53	DJ53-XFP-LC.S80	195.3	1535.04
54	DJ54-XFP-LC.S80	195.4	1534.25
55	DJ55-XFP-LC.S80	195.5	1533.47
56	DJ56-XFP-LC.S80	195.6	1532.68

57	DJ57-XFP-LC.S80	195.7	1531.90
58	DJ58-XFP-LC.S80	195.8	1531.12
59	DJ59-XFP-LC.S80	195.9	1530.33
60	DJ60-XFP-LC.S80	196.0	1529.55

*Contact DCI for the wavelength availability.

Regulatory Compliance

Feature	Standard	Performance
Electrostatic Discharge (ESD) to the Electrical Pins	MIL-STD-883G Method 3015.7	Class 1C (>1000V)
Electrostatic Discharge to the enclosure	EN 55024:1998+A1+A2 IEC-61000-4-2 GR-1089-CORE	Compliant with standards
Electromagnetic Interference (EMI)	FCC Part 15 Class B EN55022:2006 CISPR 22B :2006 VCCI Class B	Compliant with standards Noise frequency range: 30MHz to 6GHz. Good system EMI design practice required to achieve Class B margins. System margins are dependent on customer host board and chassis design.
Immunity	EN 55024:1998+A1+A2 IEC 61000-4-3	Compliant with standards. 1KHz sine-wave, 80% AM, from 80MHz to 1GHz. No effect on transmitter/receiver performance is detectable between these limits.
Laser Eye Safety	FDA 21CFR 1040.10 and 1040.11 EN (IEC) 60825-1:2007 EN (IEC) 60825-2:2004+A1	CDRH compliant and Class I laser product. TüV Certificate No. 50135086
Component Recognition	UL and CUL EN60950-1:2006	UL file E317337 TüV Certificate No. 50135086 (CB scheme)
RoHS6	2002/95/EC 4.1&4.2 2005/747/EC 5&7&13	Compliant with standards ^{*note3}

Note2: In light of item 5 in RoHS exemption list of RoHS Directive 2002/95/EC, Item 5: Lead in glass of cathode ray tubes, electronic components and fluorescent tubes.

In light of item 13 in RoHS exemption list of RoHS Directive 2005/747/EC, Item13: Lead and cadmium in optical and filter glass. The three exemptions are being concerned for our transceivers, because our transceivers use glass, which may contain Pb, for components such as lenses, windows, isolators, and other electronic components.

Absolute Maximum Ratings

Parameter	Symbol	Min	Typ	Max	Unit
Maximum Supply Voltage 1	Vcc3	-0.5		4.0	V
Maximum Supply Voltage 2	Vcc5	-0.5		6.0	V
Storage Temperature	T _s	-40		85	°C
Case Operating Temperature	T _c	-5		70	°C
Maximum Input Power	P _m			-8	dBm

Recommend operating condition

Parameter	Symbol	Min	Typ	Max	Units
Operating Case Temperature	T _c	-5		70	°C
Supply Voltage 1	Vcc3	3.13	3.3	3.45	V
Supply Voltage 2	Vcc5	4.75	5	5.25	V

Electrical Characteristics

(T_c = -5 to 70°C)

Parameter	Symbol	Min	Typ	Max	Unit
Main Supply Voltage	Vcc5	4.75		5.25	V
Supply Voltage #2	Vcc3	3.13		3.45	V
Supply Current – Vcc5 supply	Icc5			400	mA
Supply Current – Vcc3 supply	Icc3			700	mA
Module Total Power	P		3.5		W
Transmitter					
Input Differential Impedance	R _{in}		100		Ω
Differential Data Input Swing ^{*3}	V _{in} , pp	120		820	mV
Transmit Disable Voltage	VD	2.0		Vcc	V
Transmit Enable Voltage	VEN	GND		GND+ 0.8	V
Transmit Disable Assert Time				10	us
Receiver					
Differential Data Output Swing ^{*3}	V _{out} , pp	340	650	850	mV
Rise Time (20~80%)	t _r			38	ps
Fall Time (20~80%)	t _f			39	ps
LOS Fault ^{*4}	VLOS fault	Vcc – 0.5		VccHOST	V
LOS Normal ^{*4}	VLOS norm	GND		GND+0.5	V

Note3. After internal AC coupling.

Note4. Loss of signal is open collector output. Logic 0 indicates normal operation; logic 1 indicates no signal detected.

Optical Characteristics

 (T_c= -5 to 70C)

Parameter	Symbol	Min	Typ	Max	Unit
Transmitter					
Output Opt. Pwr: 9/125 SMF	P _{out}	0		+4	dBm
Frequency Range	-	191.7		196.1	THz
Center Wavelength Spacing	λ _c		100		GHz
Center Frequency Spacing	f _c		0.8		nm
Transmitter Center Wavelength End Of Life	λ	X-100	X	X+100	pm
Transmitter Center Wavelength Beginning Of Life	λ	X-25	X	X+25	pm
Optical Extinction Ratio	ER	9			dB
Dispersion Tolerance	DT			1600	ps/nm
Average Launch Power of OFF transmitter	P _{OFF}			-30	dBm
TX Jitter Generation (Peak-to-Peak)	T _{xj}			0.1	UI
TX Jitter Generation (RMS)	T _{xj} RMS			0.01	UI
Receiver					
Optical Center Wavelength	λ _c	1520		1600	nm
Receive Sensitivity @ 10.7Gbps	P _{in}			-24	dBm
Receive Overload @ 10.7Gbps	P _{in}	-7			dBm
Receiver Reflectance	R _{rx}			-27	dB
Dispersion Penalty				2	dB
LOS De-Assert	LOSD			-26	dBm
LOS Assert	LOSA	-38			dBm
LOS Hysteresis		0.5			Db

Pin Descriptions

Pin	Symbol	Name/Description	Note
1	GND	Module Ground	5
2	VEE5	Optional -5.2 Power Supply – Not required	
3	Mod-Desel	Module De-select; When held low allows the module to respond to 2-wire serial interface commands	
4	Interrupt	Interrupt (bar); Indicates presence of an important condition which can be read over the serial 2-wire interface	6
5	TX_DIS	Transmitter Disable; Transmitter laser source turned off	
6	VCC5	+5 Power Supply	
7	GND	Module Ground	5
8	VCC3	+3.3V Power Supply	

9	VCC3	+3.3V Power Supply	
10	SCL	Serial 2-wire interface clock	6
11	SDA	Serial 2-wire interface data line	6
12	Mod_Abs	Module Absent; Indicates module is not present. Grounded in the module.	6
13	Mod_NR	Module Not Ready;	6
14	RX_LOS	Receiver Loss of Signal indicator	6
15	GND	Module Ground	5
16	GND	Module Ground	5
17	RD-	Receiver inverted data output	
18	RD+	Receiver non-inverted data output	
19	GND	Module Ground	5
20	VCC2	+1.8V Power Supply – Not required	
21	P_Down/RS T	Power Down; When high, places the module in the low power stand-by mode and on the falling edge of P_Down initiates a module reset	
		Reset; The falling edge initiates a complete reset of the module including the 2-wire serial interface, equivalent to a power cycle.	
22	VCC2	+1.8V Power Supply – Not required	
23	GND	Module Ground	5
24	RefCLK+	Reference Clock non-inverted input, AC coupled on the host board – Not required	7
25	RefCLK-	Reference Clock inverted input, AC coupled on the host board – Not required	7
26	GND	Module Ground	5
27	GND	Module Ground	5
28	TD-	Transmitter inverted data input	
29	TD+	Transmitter non-inverted data input	
30	GND	Module Ground	5

Note5. Module circuit ground is isolated from module chassis ground within the module.

Note6. Open collector; should be pulled up with 4.7k – 10k ohm on host board to a voltage between 3.15V and 3.6V.

Note7. A Reference Clock input is not required.

Pin arrangement

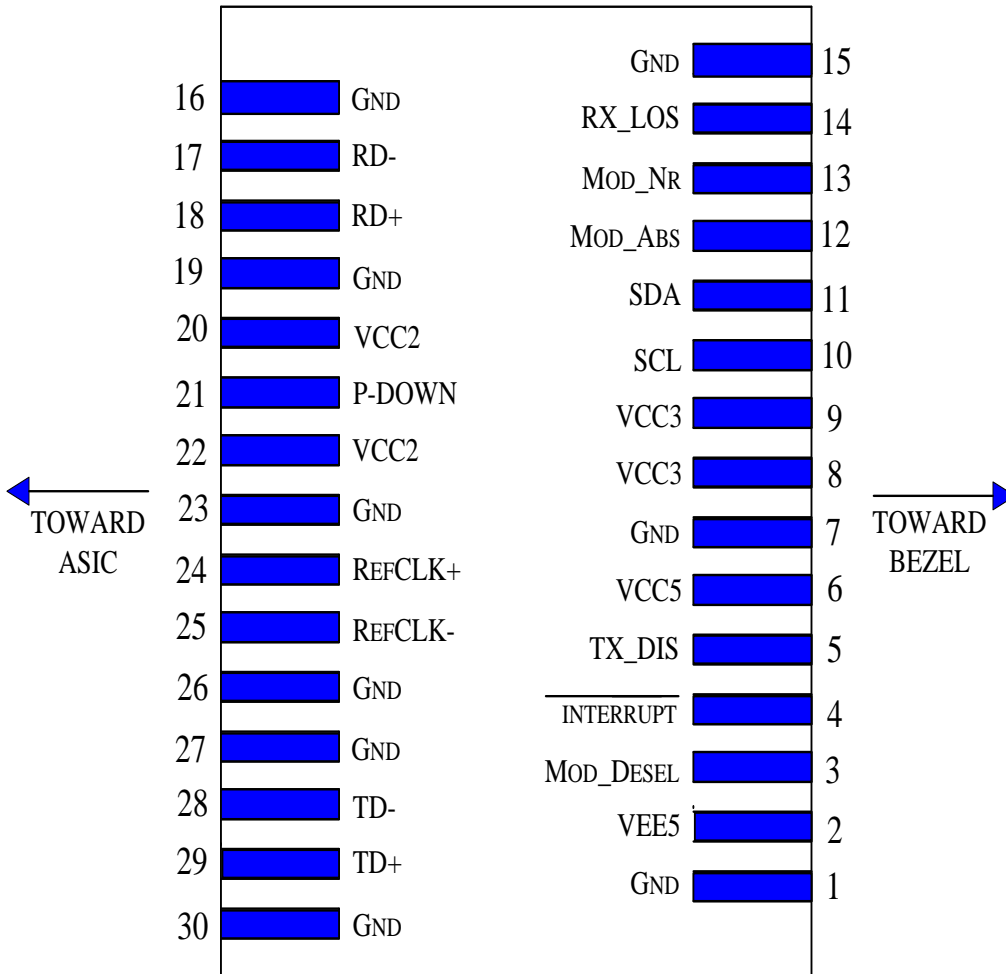

Pin Numbers and Name

General Specifications

Parameter	Symbol	Min	Typ	Max	Units	Note
Bit Rate	BR	9.95		11.1	Gb/s	8
Bit Error Ratio	BER			10 ⁻¹²		9

Note8. SONET OC-192 IR-2, OC-192 IR-3, ITU-T G.709, 10GBASE-ZR/ZW + FEC, 10G Fiber Channel

Note9. Tested with a 2³¹ – 1 PRBS

Digital Diagnostic Functions

DJxx-XFP-LC.S80 Small Form Factor 10Gbps (XFP) transceivers are compliant with the current XFP Multi-Source Agreement (MSA) Specification Rev 4.5.

As defined by the XFP MSA, XFP transceivers provide digital diagnostic functions via a 2-wire serial interface, which allows real-time access to the following operating parameters:

- ◆ Transceiver temperature
- ◆ Laser bias current
- ◆ Transmitted optical power
- ◆ Received optical power
- ◆ Transceiver supply voltage
- ◆ Laser temperature

It also provides a sophisticated system of alarm and warning flags, which may be used to alert end-users when particular operating parameters are outside of a factory-set normal range.

The operating and diagnostics information is monitored and reported by a Digital Diagnostics Transceiver Controller inside the transceiver, which is accessed through the 2-wire serial interface. When the serial protocol is activated, the serial clock signal (SCL pin) is generated by the host. The positive edge clocks data into the XFP transceiver into those segments of its memory map that are not write-protected. The negative edge clocks data from the XFP transceiver. The serial data signal (SDA pin) is bi-directional for serial data transfer. The host uses SDA in conjunction with SCL to mark the start and end of serial protocol activation. The memories are organized as a series of 8-bit data words that can be addressed individually or sequentially. The 2-wire serial interface provides sequential or random access to the 8 bit parameters, addressed from 000h to the maximum address of the memory.

Table 1 Serial ID Memory Contents (Table 01h)

Addr.	Size (Bytes)	Name of Field	Hex	Description
128	1	Identifier	06	XFP
129	1	Ext. Identifier	90	power consumption < 3.5W, no Ref Colck required
130	1	Connector	07	LC Connector
131~138	8	Transceiver	00 00 00 00 00 00 04 00	Transmitter Code
139	1	Encoding	F0	64B/66B, 8B/10B,SONET Scrambled, NRZ
140	1	BR-Min	63	9.95Gbps
141	1	BR-Max	6F	11.1Gbps
142	1	Length (SMF)km	50	Transceiver transmits 80km.
143	1	Length (E-50µm)	00	
144	1	Length (50µm)	00	
145	1	Length(62.5µm)	00	
146	1	Length (Copper)	00	Not compliant
147	1	Device Tech	76	1550 EML, APD detector

148~163	16	Vendor name	Data Controls	
164	1	CDR Support	FF	FF with 10G CDR
165~167	3	Vendor OUI	68F125	
168~183	16	Vendor PN	DJxxXFPLCS80	
184~185	2	Vendor rev	XX XX XX XX ^(note)	
186~187	2	Wavelength Tolerance	XX XX ^(note)	Centre Wavelength
188~189	2	Wavelength Tolerance	00 14	+/- 0.1 nm
190	1	Max Case Temp	46	70deg
191	1	CC_BASE	XX ^(note)	Check sum of Byte 128 – 190
192~195	4	Power Supply	AF 96 98 00	Max current required by +5V Supply(Ma): 450 , Max current required by +3.3V Supply(Ma): 800
196~211	16	Vendor SN	XX XX XX XX XX XX XX XX XX XX XX XX XX XX XX XX ^(note)	
212~219	8	Date Code	XX XX XX XX XX XX XX XX ^(note)	
220	1	Diagnostic Monitoring Type	08	No BER Support, Average Power
221	1	Enhanced Options	60	Optional Soft TX_DISABLE implemented, Optional Soft P_down implemented
222	1	Aux Monitoring	60	Aux A/D input 1: Laser Temperature, Aux A/D input 2: +5V Supply Voltage
223	1	CC_EXT	XX ^(note)	
224~255	32	Vendor Specific	Reserved	Check sum for Extended ID Field.

NOTE: "XX" is referred to be variable.

Recommended Host Board Power Supply Circuit

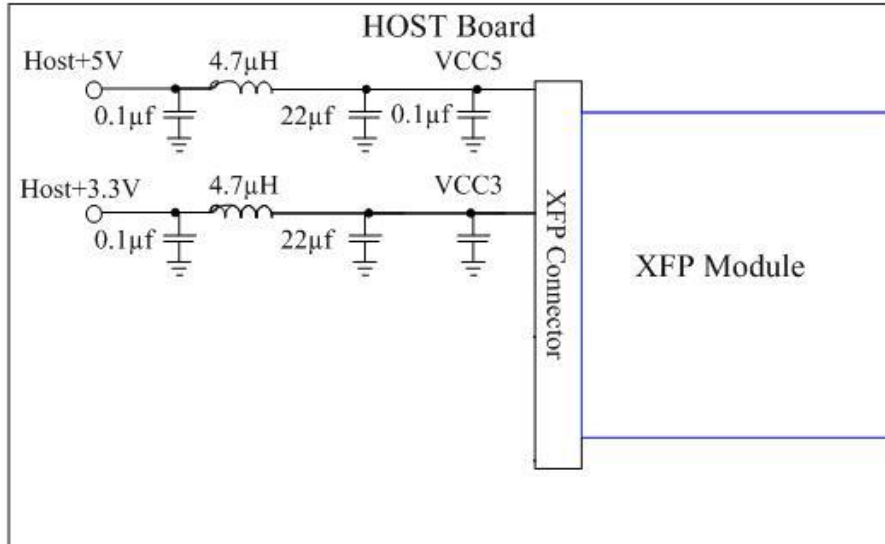

Recommended High-Speed Interface Circuit

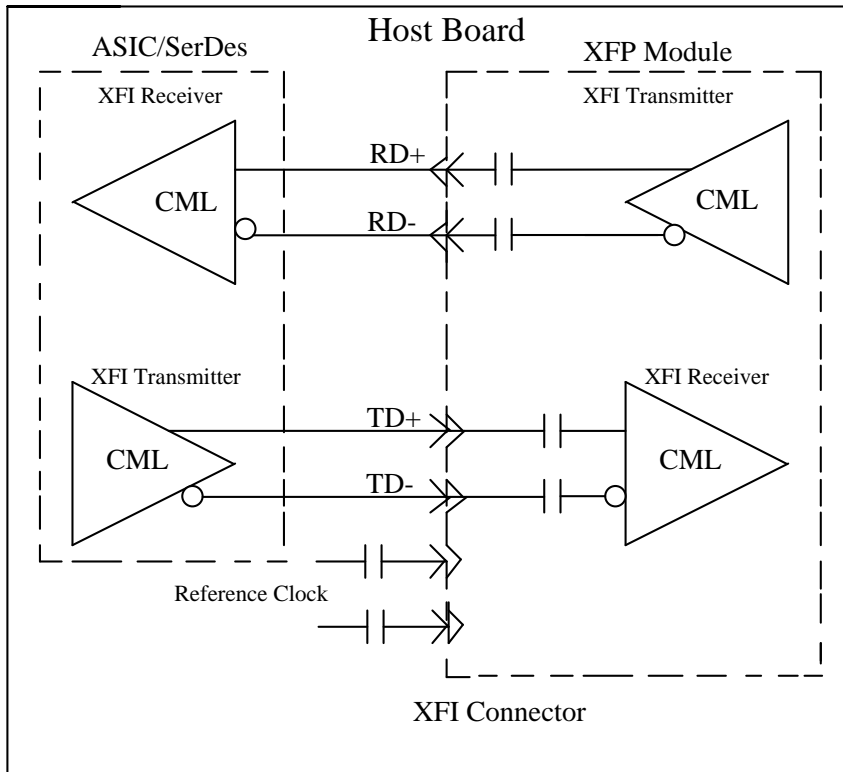

Mechanical Specifications

XFP transceivers are compliant with the dimensions defined by the XFP Multi-Sourcing Agreement (MSA).

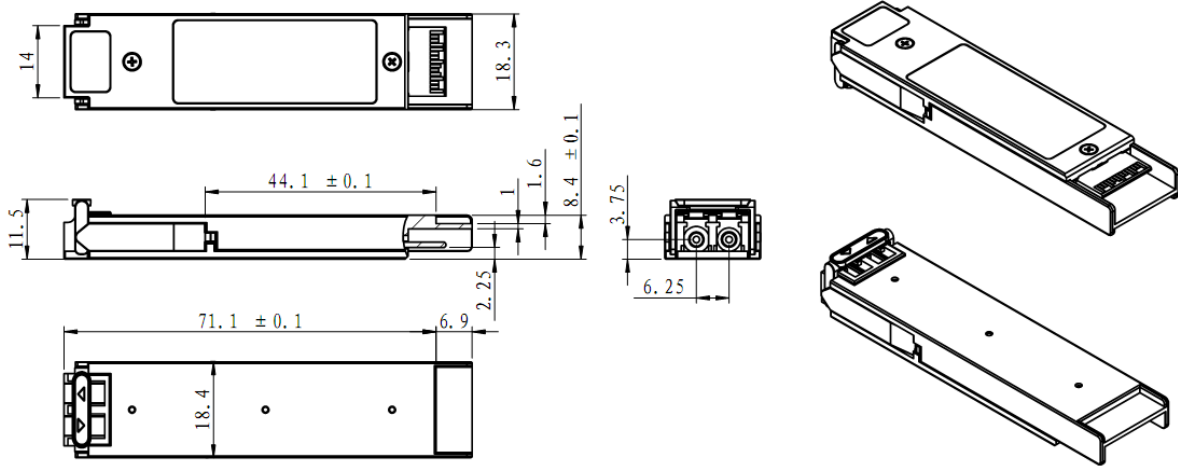

Eye Safety

This single-mode transceiver is a Class 1 laser product. It complies with IEC-60825 and FDA 21 CFR 1040.10 and 1040.11. The transceiver must be operated within the specified temperature and voltage limits. The optical ports of the module shall be terminated with an optical connector or with a dust plug.

Contact

Data Controls Inc.

sales@dcj.jp www.dci.jp