

RoHS Compliant
TX-1310/RX-1550 nm Single-mode Bi-directional (20 dB margin)
SFP LC Simplex Connector, with Diagnostic Monitoring
1.0625Gbd Fiber Channel/1.25 Gigabit Ethernet



Features

- Compliant with IEEE802.3z Gigabit Ethernet Standard
- Compliant with Fiber Channel 100-SM-LC-L standard
- Multi rate 125Mbps to 1.25Gbps
- Industry standard small form pluggable (SFP) package
- Simplex LC connector
- Differential LVPECL inputs and outputs
- Single power supply 3.3V
- TTL signal detect indicator
- Hot Pluggable
- Class 1 laser product complies with EN 60825-1

Ordering Information

| PART NUMBER | TX/RX | TEMPERATURE | LD Type | Distance |
|-----------------------|-----------|---------------|----------|----------|
| GB1310-SFP-LC.S40 | 1310/1550 | 0°C to 70°C | 1310 DFB | 40km |
| GB1310-SFP-LC.S40(WT) | 1310/1550 | -40°C to 85°C | 1310 DFB | 40km |

Diagnostics

| Parameter | Range | Accuracy | Unit | Calibration |
|--------------|-----------|----------|------|-------------|
| Temperature | -40 to 95 | ± 3 | °C | External |
| Voltage | 0 to VCC | ± 0.1 | V | |
| Bias Current | 0 to 120 | ± 5 | mA | |
| TX Power | -6 to +5 | ± 3 dB | dBm | |
| RX Power | -23 to -3 | ± 3 dB | dBm | |



RoHS Compliant
TX-1310/RX-1550 nm Single-mode Bi-directional (20 dB margin)
SFP LC Simplex Connector, with Diagnostic Monitoring
1.0625Gbd Fiber Channel/1.25 Gigabit Ethernet

Absolute Maximum Ratings

| PARAMETER | SYMBOL | MIN | MAX | UNITS | NOTE |
|---------------------|----------|------|----------|-------|------|
| Storage Temperature | T_S | -40 | 85 | °C | |
| Supply Voltage | V_{CC} | -0.5 | 4.0 | V | |
| Input Voltage | V_{IN} | -0.5 | V_{CC} | V | |
| Output Current | I_o | --- | 50 | mA | |
| Operating Current | I_{OP} | --- | 400 | mA | |

Recommended Operating Conditions

| PARAMETER | SYMBOL | MIN | MAX | UNITS | NOTE |
|----------------------------|-------------------|-----------------|-----------------|-------|--|
| Case Operating Temperature | T_C | $\frac{0}{-40}$ | $\frac{70}{85}$ | °C | <u>GB1310-SFP-LCS40</u> <u>GB1310-SFP-LCS40(WT)</u> |
| Supply Voltage | V_{CC} | 3.1 | 3.5 | V | |
| Supply Current | $I_{TX} + I_{RX}$ | --- | 300 | mA | |



RoHS Compliant
TX-1310/RX-1550 nm Single-mode Bi-directional (20 dB margin)
SFP LC Simplex Connector, with Diagnostic Monitoring
1.0625Gbd Fiber Channel/1.25 Gigabit Ethernet

Transmitter Electro-optical Characteristics

$V_{CC} = 3.1\text{ V to }3.5\text{ V}$, $T_C = 0^\circ\text{C to }70^\circ\text{C}$ ($-40^\circ\text{C to }85^\circ\text{C}$)

| PARAMETER | SYMBOL | MIN | TYP. | MAX | UNITS | NOTE |
|---|-----------------|------|------|----------|---------------|---------------------------|
| Output Optical Power 9/125 μm fiber | P_{out} | -3 | --- | +2 | dBm | Average |
| Extinction Ratio | ER | 9 | --- | --- | dB | |
| Center Wavelength | λ_C | 1290 | 1310 | 1330 | nm | |
| Spectral Width (-20dB) | $\Delta\lambda$ | --- | --- | 1 | nm | |
| Side Mode Suppression Ratio | $SMSR$ | 30 | | | dB | |
| Rise/Fall Time, (20–80%) | $T_{r,f}$ | --- | --- | 260 | ps | |
| Relative Intensity Noise | RIN | --- | --- | -120 | dB/Hz | |
| Total Jitter | TJ | --- | --- | 227 | ps | |
| Output Eye | | | | | | Compliant with IEEE802.3z |
| Max. P_{out} TX-DISABLE Asserted | P_{OFF} | --- | --- | -45 | dBm | |
| Differential Input Voltage | V_{DIFF} | 0.4 | --- | 2.0 | V | |
| Transmit Fault Output-Low | TX_FAULT_L | 0.0 | --- | 0.5 | V | |
| Transmit Fault Output-High | TX_FAULT_H | 2.4 | --- | V_{CC} | V | |
| Time to initialize, include reset of TX_FAULT | t_{init} | --- | --- | 300 | ms | |
| TX_FAULT from fault to assertion | t_{fault} | --- | --- | 100 | μs | |
| TX_DISABLE time to start reset | t_{reset} | 10 | --- | --- | μs | |

Receiver Electro-optical Characteristics

$V_{CC} = 3.1\text{ V to }3.5\text{ V}$, $T_C = 0^\circ\text{ C to }70^\circ\text{ C}$ ($-40^\circ\text{ C to }85^\circ\text{ C}$)

| PARAMETER | SYMBOL | MIN | TYP. | MAX | UNITS | NOTE |
|--|-------------|------|------|----------|-------|---------------------------------|
| Optical Input Power-maximum | P_{IN} | -1 | --- | --- | dBm | BER < 10^{-12} |
| RX Sensitivity @GbE | P_{IN} | --- | --- | -23 | dBm | PRBS7, BER < 10^{-12} |
| RX Sensitivity @1x FC | P_{IN} | --- | --- | -23 | dBm | PRBS7, BER < 10^{-12} |
| RX Sensitivity @OC-12 | P_{IN} | --- | --- | -23 | dBm | PRBS23, BER < 10^{-10} |
| RX Sensitivity @OC-3 | P_{IN} | --- | --- | -23 | dBm | PRBS23, BER < 10^{-10} |
| RX Sensitivity @125Mbps | P_{IN} | --- | --- | -23 | dBm | PRBS7, BER < 10^{-10} |
| Operating Center Wavelength | λ_C | 1480 | --- | 1580 | nm | |
| Optical Return Loss | ORL | 14 | --- | --- | dB | $\lambda=1480\sim1580\text{nm}$ |
| Optical isolation | ISO | --- | --- | -45 | dB | $\lambda=1260\sim1360\text{nm}$ |
| Signal Detect-Asserted | P_A | --- | --- | -23 | dBm | |
| Signal Detect-Deasserted | P_D | -35 | --- | --- | dBm | |
| Differential Output Voltage | V_{DIFF} | 0.5 | --- | 1.2 | V | |
| Data Output Rise, Fall Time (20–80%) | $T_{r,f}$ | --- | --- | 0.35 | ns | |
| Receiver Loss of Signal Output Voltage-Low | RX_LOS_L | 0 | --- | 0.5 | V | |
| Receiver Loss of Signal Output Voltage-High | RX_LOS_H | 2.4 | --- | V_{CC} | V | |

Block Diagram of Transceiver

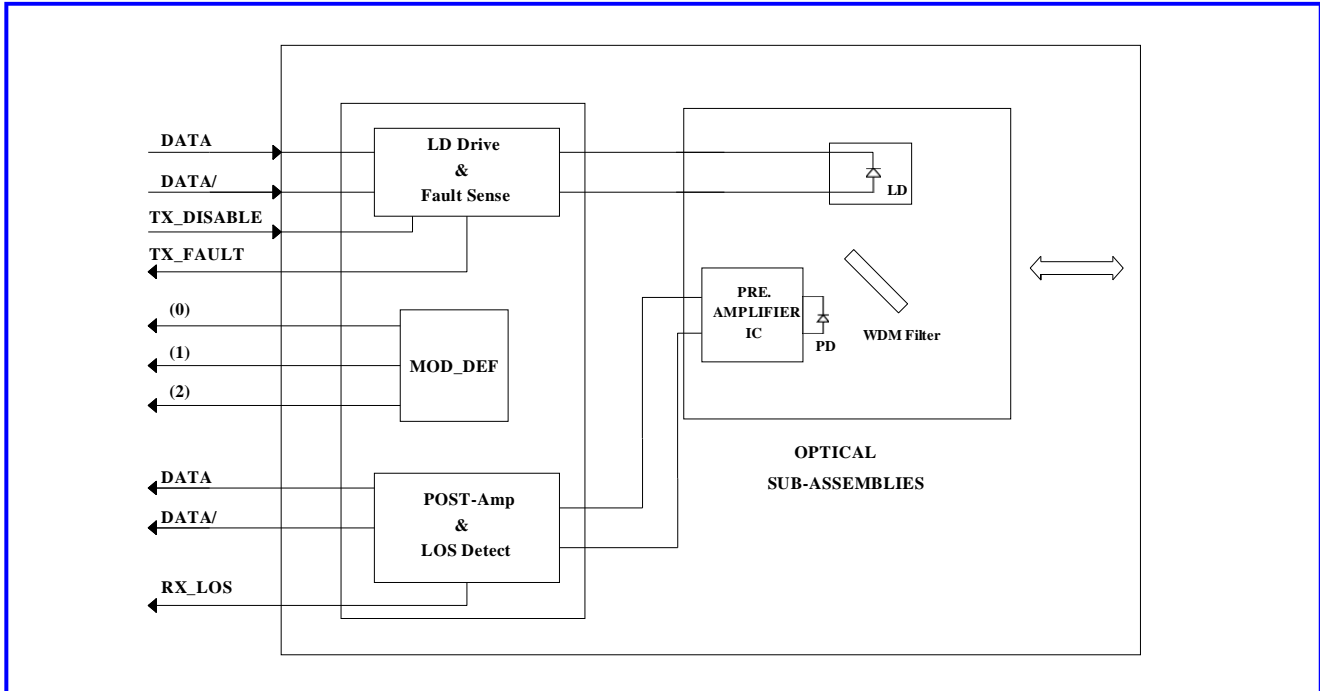

Transmitter and Receiver Optical Sub-assembly Section

A 1310 nm InGaAsP laser and an InGaAs PIN photodiode integrate with an WDM filter to form a bi-directional single fiber optical subassembly (OSA). The laser of OSA is driven by a LD driver IC which converts differential input LVPECL logic signals into an analog laser driving current. And, The photodiode of OSA is connected to a circuit providing post-amplification quantization, and optical signal detection.

TX_FAULT

When sensing an improper power level in the laser driver, the SFP set this signal high and turns off the Laser. TX_FAULT can be reset with the TX_DISABLE line. The signal is in TTL level.

TX_DISABLE

The TX_DISABLE signal is high (TTL logic "1") to turn off the laser output.

Receive Loss (RX_LOS)

The RX_LOS is high (logic "1") when there is no incoming light from the companion transceiver. This signal is normally used by the system for the diagnostic purpose. The signal is operated in TTL level.

Dimensions

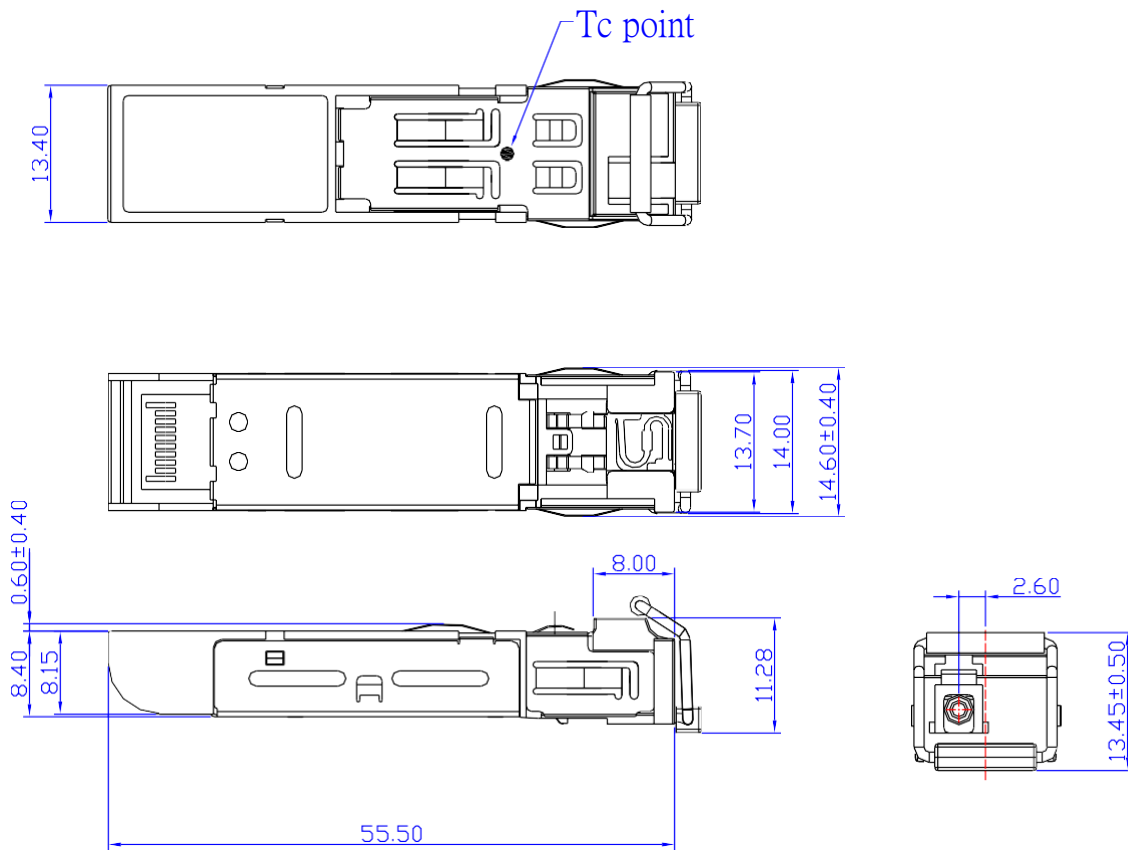

DIMENSIONS ARE IN MILLIMETERS

ALL DIMENSIONS ARE 0.2mm UNLESS OTHERWISE SPECIFIED

±

RoHS Compliant
TX-1310/RX-1550 nm Single-mode Bi-directional (20 dB margin)
SFP LC Simplex Connector, with Diagnostic Monitoring
1.0625Gbd Fiber Channel/1.25 Gigabit Ethernet

SFP host board mechanical layout

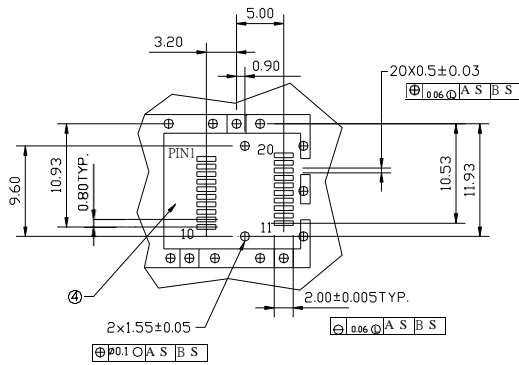
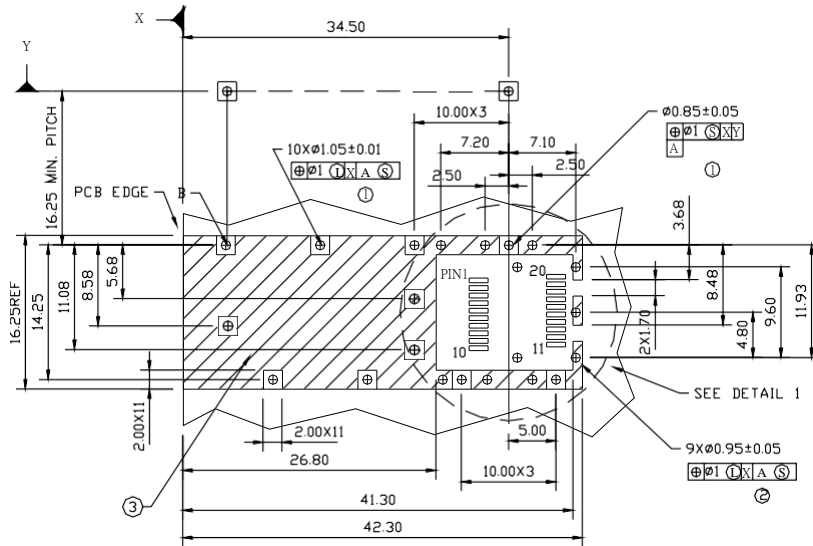

DETAIL 1

LEGEND

1. PADS AND VIAS ARE CHASSIS GROUND
2. THROUGH HOLES, PLATING OPTIONAL
3. HATCHED AREA DENOTES COMPONENT AND TRACE KEEP-OUT (EXCEPT CHASSIS GROUND)
4. AREA DENOTES COMPONENT KEEP-OUT (TRACES ALLOWED)

DIMENSIONS ARE IN MILLIMETERS

Unit: mm

RoHS Compliant
TX-1310/RX-1550 nm Single-mode Bi-directional (20 dB margin)
SFP LC Simplex Connector, with Diagnostic Monitoring
1.0625Gbd Fiber Channel/1.25 Gigabit Ethernet

Assembly drawing

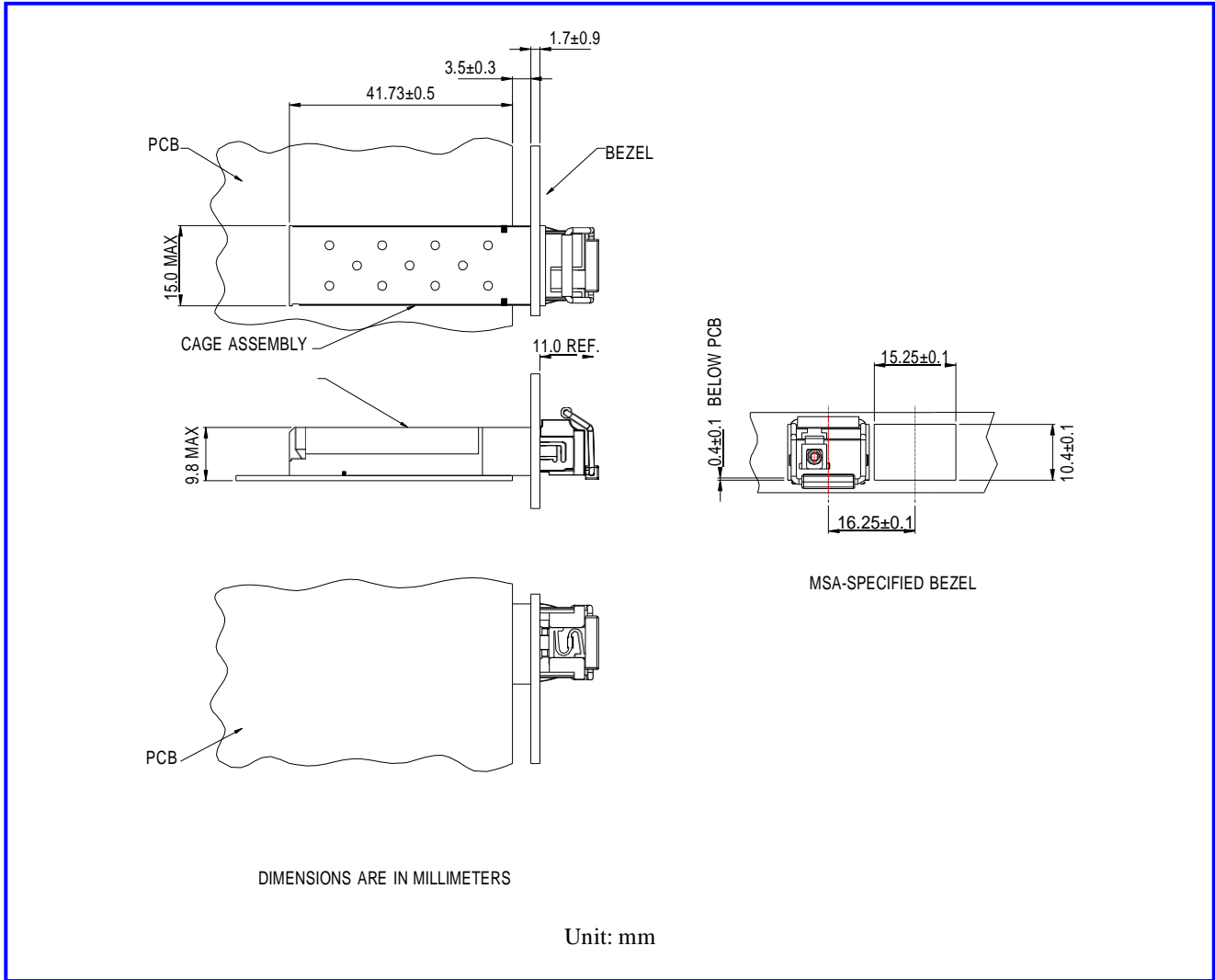

Pin Assignment

Pin-Out

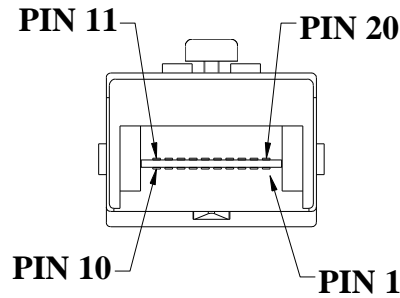

| Pin | Signal Name | Description |
|-----|----------------|---|
| 1 | T_{GND} | Transmit Ground |
| 2 | TX_FAULT | Transmit Fault |
| 3 | $TX_DISABLE$ | Transmit Disable |
| 4 | $MOD_DEF (2)$ | SDA Serial Data Signal |
| 5 | $MOD_DEF (1)$ | SCL Serial Clock Signal |
| 6 | $MOD_DEF (0)$ | TTL Low |
| 7 | $RATE_SELECT$ | Open Circuit |
| 8 | RX_LOS | Receiver Loss of Signal, TTL High, open collector |
| 9 | R_{GND} | Receiver Ground |
| 10 | R_{GND} | Receiver Ground |
| 11 | R_{GND} | Receiver Ground |
| 12 | $RX-$ | Receive Data Bar, Differential PECL, ac coupled |
| 13 | $RX+$ | Receive Data, Differential PECL, ac coupled |
| 14 | R_{GND} | Receiver Ground |
| 15 | V_{CCR} | Receiver Power Supply |
| 16 | V_{CCT} | Transmitter Power Supply |
| 17 | T_{GND} | Transmitter Ground |
| 18 | $TX+$ | Transmit Data, Differential PCEL, ac coupled |
| 19 | $TX-$ | Transmit Data Bar, Differential PCEL, ac coupled |
| 20 | T_{GND} | Transmitter Ground |

RoHS Compliant
TX-1310/RX-1550 nm Single-mode Bi-directional (20 dB margin)
SFP LC Simplex Connector, with Diagnostic Monitoring
1.0625Gbd Fiber Channel/1.25 Gigabit Ethernet

Eye Safety Mark

The GB1310-SFP-LC.S40 singlemode transceiver is a class 1 laser product. It complies with EN 60825-1 and FDA 21 CFR 1040.10 and 1040.11. In order to meet laser safety requirements the transceiver shall be operated within the Absolute Maximum Ratings.

Caution

All adjustments have been done at the factory before the shipment of the devices. No maintenance and user serviceable part is required. Tampering with and modifying the performance of the device will result in voided product warranty.

Required Mark

**Class 1 Laser Product
Complies with
21 CFR 1040.10 and 1040.11**

Note : All information contained in this document is subject to change without notice.