

**GB1310-SFP-LC.S10**
**GB1550-SFP-LC.S10**
**GB1310-SFP-SC.S10**
**GB1550-SFP-SC.S10**

Single-Mode 100Mbps to 1.25Gbps FE/GBE /FC  
 SC/LC Single-Fiber SFP Transceiver  
 RoHS6 Compliant



### Features

- ◆ Support 1.25Gbps Data Links
- ◆ A type: 1310nm FP TX /1550nm RX  
 B type: 1550nm DFB TX /1310nm RX
- ◆ 10km with 9/125 μm SMF
- ◆ Single 3.3V Power supply and TTL Logic Interface
- ◆ Hot-Pluggable SFP Footprint Simplex SC/LC Connector Interface
- ◆ Class 1 FDA and IEC60825-1 Laser Safety Compliant
- ◆ Operating Case Temperature  
 Standard: 0°C~+70°C#  
 Industrial:-40°C~+85°C#
- ◆ Compliant with SFP MSA Specification
- ◆ Compliant with Digital Diagnostic Monitor Interface

SFF-8472

### Applications

- ◆ Fiber Channel Links
- ◆ WDM Gigabit Ethernet Links
- ◆ Other Optical Links
- ◆ FTTX Application

### Ordering Information

Part No.	Data Rate	Wavelength	Interface	Temp.	DDMI
GB1310-SFP-SC.S10	1.063/1.25Gbps	1310nm	SC	Standard	YES
GB1550-SFP-SC.S10	1.063/1.25Gbps	1550nm	SC	Standard	YES
GB1310-SFP-SC.S10(WT)	1.063/1.25Gbps	1310nm	SC	Industrial	YES
GB1550-SFP-SC.S10(WT)	1.063/1.25Gbps	1550nm	SC	Industrial	YES

GB1310-SFP-LC.S10	1.063/1.25Gbps	1310nm	LC	Standard	YES
GB1550-SFP-LC.S10	1.063/1.25Gbps	1550nm	LC	Standard	YES
GB1310-SFP-LC.S10(WT)	1.063/1.25Gbps	1310nm	LC	Industrial	YES
GB1550-SFP-LC.S10(WT)	1.063/1.25Gbps	1550nm	LC	Industrial	YES

Note1: Standard version

\*The product image only for reference purpose.

## Regulatory Compliance <sup>\*Note2</sup>

Product Certificate	Certificate Number	Applicable Standard
TUV	R50135086	EN 60950-1:2006+A11+A1+A12+A2
		EN 60825-1:2014
		EN 60825-2:2004+A1+A2
UL	E317337	UL 60950-1
		CSA C22.2 No. 60950-1-07
EMC CE	AE 50285865 0001	EN 55022:2010
		EN 55024:2010
FCC	WTF14F0514417E	47 CFR PART 15 OCT., 2013
FDA	/	CDRH 1040.10
ROHS	/	2011/65/EU

Note2: The above certificate number updated to June 2014, because some certificate will be updated every year, such as FDA and ROHS. For the latest certification information, please check with Data Controls Inc..

## Product Description

GB1310/1550-SFP-LC/SC.S10 series is small form factor pluggable module for Gigabit Ethernet 1000BASE-BX and Fiber Channel single fiber applications by using 1310nm / 1550nm transmitter and 1550nm / 1310nm receiver. It is with the SFP 20-pin connector to allow hot plug capability.

The transmitter section uses a multiple quantum well A type / B type laser and is a class 1 laser compliant according to International Safety Standard IEC 60825. The receiver section uses an integrated B type / A type detector preamplifier (IDP) mounted in an optical header and a limiting post-amplifier IC.

GB1310/1550-SFP-LC/SC.S10 series are designed to be compliant with SFF-8472 Multi-source Agreement (MSA).

### Absolute Maximum Ratings

Parameter	Symbol	Min.	Max.	Unit
Storage Temperature	Ts	-40	+85	°C
Supply Voltage	Vcc	-0.5	3.6	V
Operating Relative Humidity		-	95	%

\*Exceeding any one of these values may destroy the device immediately.

### Recommended Operating Conditions

Parameter	Symbol	Min.	Typical	Max.	Unit
Operating Case Temperature	Tc	GB1310/1550-SFP	0	+70	°C
		GB1310/1550-SFP(WT)	-40	+85	
Power Supply Voltage	Vcc	3.15	3.3	3.45	V
Power Supply Current	Icc			300	mA
Data Rate	FC		1.063		Gbps
	GBE		1.25		Gbps

### Performance Specifications - Electrical

Parameter	Symbol	Min.	Typ.	Max	Unit	Notes
<b>Transmitter</b>						
LVPECL Inputs(Differential)	Vin	400		2000	mVpp	AC coupled inputs*(note5)
Input Impedance (Differential)	Zin	85	100	115	ohm	Rin > 100 kohm @ DC
TX_Dis	Disable	2		Vcc+0.3	V	
	Enable	0		0.8		
TX_FAULT	Fault	2		Vcc+0.3	V	
	Normal	0		0.5		
<b>Receiver</b>						
LVPECL Outputs (Differential)	Vout	400		2000	mVpp	AC coupled outputs*(note5)
Output Impedance (Differential)	Zout	85	100	115	ohm	
RX_LOS	LOS	2		Vcc+0.3	V	
	Normal	0		0.8	V	
MOD_DEF ( 0:2 )	VoH	2.5			V	With Serial ID
	VoL	0		0.5	V	

**Optical and Electrical Characteristics**
**(GB1310-SFP-LC/SC.S10, 1310nm FP and PIN, 10km)**

Parameter	Symbol	Min.	Typical	Max.	Unit
9µm Core Diameter SMF	L		10		km
Data Rate			1063/1250		Mbps
<b>Transmitter</b>					
Center Wavelength	$\lambda_c$	1270	1310	1350	nm
Spectral Width (RMS)	$\Delta\lambda$			3.5	nm
Average Output Power*(note3)	P <sub>out</sub>	-9		-3	dBm
Extinction Ratio @ 1250Mbps	ER	6	9		dB
Rise/Fall Time(20%~80%)	t <sub>r</sub> /t <sub>f</sub>			0.26	ns
Total Jitter	TJ			260	ps
Output Optical Eye*(note4)	Compliant with IEEE 802.3ah-2004*(note7)				
TX_Disable Assert Time	t <sub>off</sub>			10	us
P <sub>out</sub> @TX Disable Asserted	P <sub>out</sub>			-45	dBm
<b>Receiver</b>					
Center Wavelength	$\lambda_c$	1530	1550	1570	nm
Receiver Sensitivity*(note6)@1250Mbps	P <sub>min</sub>			-21	dBm
Receiver Overload	P <sub>max</sub>	-3			dBm
LOS De-Assert@1250Mbps	LOSD			-22	dBm
LOS Assert	LOSA	-35			dBm
LOS Hysteresis*(note8)		0.5			dB

**(GB1550-SFP-LC/SC.S10, 1550nm DFB and PIN, 10km)**

Parameter	Symbol	Min.	Typical	Max.	Unit
9µm Core Diameter SMF	L		10		km
Data Rate			1063/1250		Mbps
<b>Transmitter</b>					
Center Wavelength	$\lambda_c$	1520	1550	1580	nm
Spectral Width (-20dB)	$\Delta\lambda$			1	nm
Side Mode Suppression Ratio	SMSR	30			dB
Average Output Power*(note3)	P <sub>out</sub>	-9		-3	dBm
Extinction Ratio @ 1250Mbps	ER	6	9		dB
Rise/Fall Time(20%~80%)	t <sub>r</sub> /t <sub>f</sub>			260	ps
Output Optical Eye*(note4)	Compliant with IEEE 802.3ah-2004*(note7)				
TX_Disable Assert Time	t <sub>off</sub>			10	us
P <sub>out</sub> @TX Disable Asserted	P <sub>out</sub>			-45	dBm
<b>Receiver</b>					
Center Wavelength	$\lambda_c$	1260		1360	nm
Receiver	P <sub>min</sub>			-21	dBm

Sensitivity*(note6)@1250Mbps				
Receiver Overload	Pmax	-3		dBm
Return Loss		12		dB
Optical Path Penalty			1	dB
LOS De-Assert@1250Mbps	LOSD		-22	dBm
LOS Assert	LOSA	-35		dBm
LOS Hysteresis*(note8)		0.5		dB

Note3: Output is coupled into a 9/125µm single-mode fiber.

Note4: Filtered, measured with a PRBS 2<sup>7</sup>-1.

Note5: LVPECL logic, internally AC coupled.

Note6: Measured at all data rates specified in Data Rate table with ER=9 dB, 27-1 PRBS data pattern, BER <1E-12.

Note7: Eye Pattern Mask

Note8: LOS Hysteresis

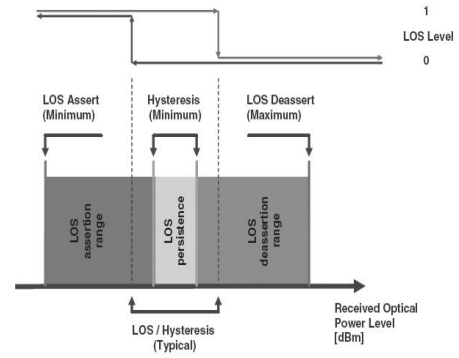
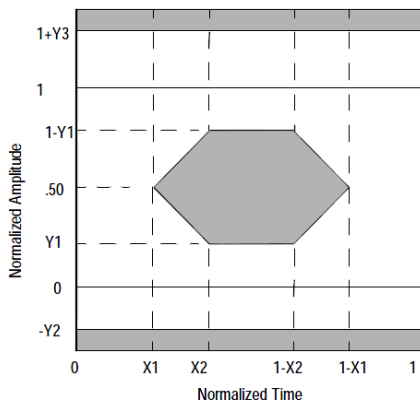

## Functional Description of Transceiver

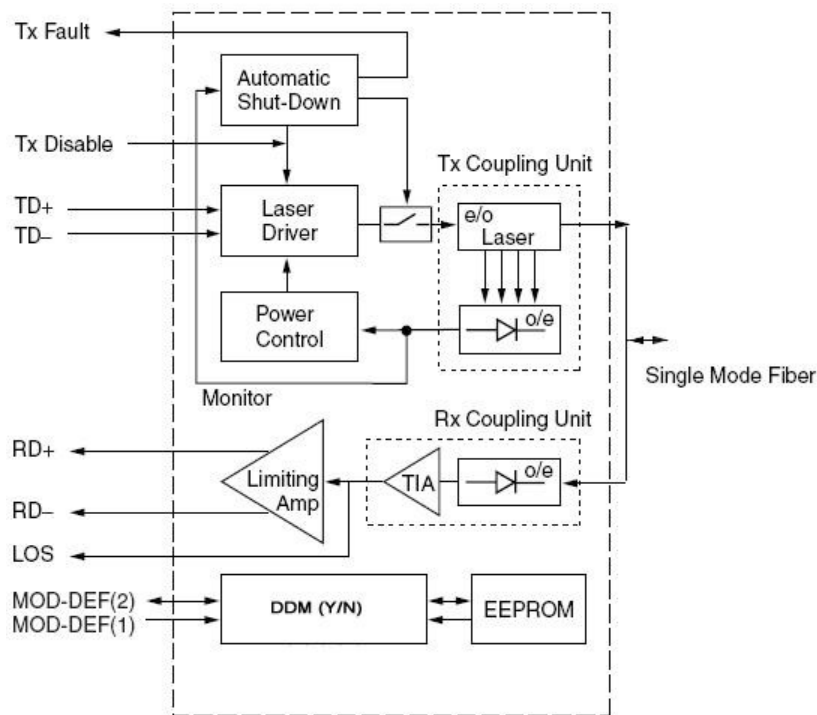

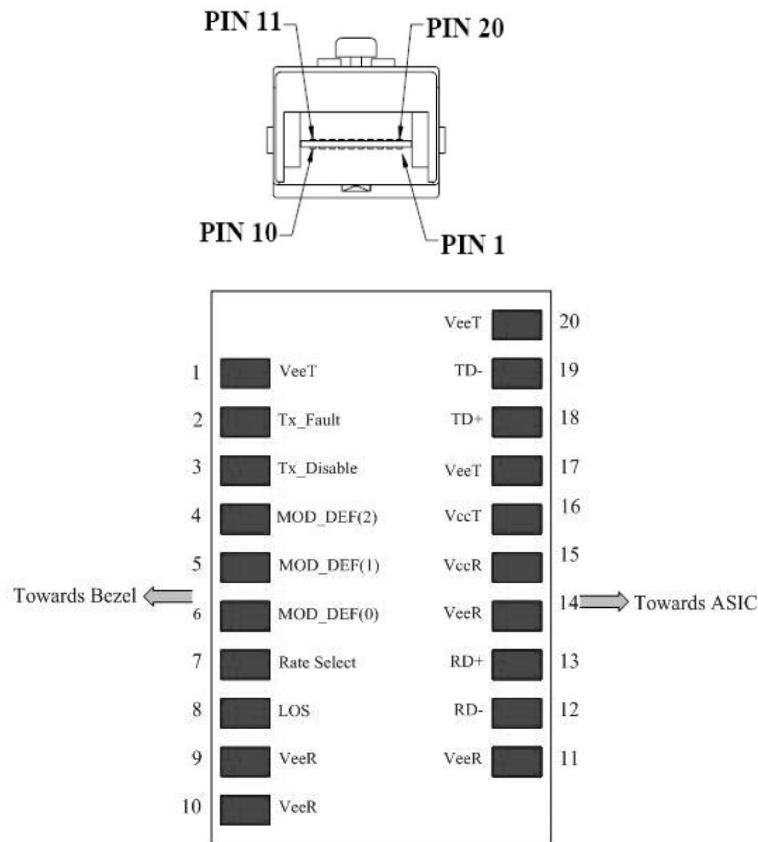
**SFP Transceiver Electrical Pad Layout**

**Pin Function Definitions**

Pin NO.	Name	Function	Plug Seq.	Notes
1	VeeT	Transmitter Ground	1	5)
2	TX Fault	Transmitter Fault Indication	3	1)
3	TX Disable	Transmitter Disable	3	2) Module disables on high or open
4	MOD-DEF2	Module Definition 2	3	3) Data line for Serial ID.
5	MOD-DEF1	Module Definition 1	3	3) Clock line for Serial ID.
6	MOD-DEF0	Module Definition 0	3	3) Grounded within the module.
7	Rate Select	Not Connect	3	Function not available
8	LOS	Loss of Signal	3	4)
9	VeeR	Receiver Ground	1	5)
10	VeeR	Receiver Ground	1	5)
11	VeeR	Receiver Ground	1	5)
12	RD-	Inv. Received Data Out	3	6)
13	RD+	Received Data Out	3	6)
14	VeeR	Receiver Ground	1	5)
15	VccR	Receiver Power	2	7) 3.3 ± 5%
16	VccT	Transmitter Power	2	7) 3.3 ± 5%

17	VeeT	Transmitter Ground	1	5)
18	TD+	Transmit Data In	3	8)
19	TD-	Inv. Transmit Data In	3	8)
20	VeeT	Transmitter Ground	1	5)

**Notes:**

1) TX Fault is an open collector/drain output, which should be pulled up with a 4.7K – 10KΩ resistor on the host board. Pull up voltage between 2.0V and VccT, R+0.3V. When high, output indicates a laser fault of some kind. Low indicates normal operation. In the low state, the output will be pulled to < 0.8V.

2) TX disable is an input that is used to shut down the transmitter optical output. It is pulled up within the module with a 4.7 – 10 KΩ resistor. Its states are:

Low (0 – 0.8V): Transmitter on

(>0.8, < 2.0V): Undefined

High (2.0 – 3.465V): Transmitter Disabled

Open: Transmitter Disabled

3) Mod-Def 0,1,2. These are the module definition pins. They should be pulled up with a 4.7K – 10K . resistor on the host board. The pull-up voltage shall be VccT or VccR .

Mod-Def 0 is grounded by the module to indicate that the module is present

Mod-Def 1 is the clock line of two wire serial interface for serial ID

Mod-Def 2 is the data line of two wire serial interface for serial ID

4) LOS (Loss of Signal) is an open collector/drain output, which should be pulled up with a 4.7K – 10KΩ resistor. Pull up voltage between 2.0V and VccT, R+0.3V. When high, this output indicates the received optical power is below the worst-case receiver sensitivity (as defined by the standard in use). Low indicates normal operation. In the low state, the output will be pulled to < 0.8V.

5) VeeR and VeeT may be internally connected within the SFP module.

6) RD-/+ : These are the differential receiver outputs. They are AC coupled 100Ω differential lines which should be terminated with 100Ω (differential) at the user SERDES. The AC coupling is done inside the module and is thus not required on the host board.

7) VccR and VccT are the receiver and transmitter power supplies. They are defined as 3.3V ±5% at the SFP connector pin. Maximum supply current is 300mA. Recommended host board power supply filtering is shown below. Inductors with DC resistance of less than 1 ohm should be used in order to maintain the required voltage at the SFP input pin with 3.3V supply voltage. When the recommended supply-filtering network is used, hot plugging of the SFP transceiver module will result in an inrush current of no more than 30mA greater than the steady state value. VccR and VccT may be internally connected within the SFP transceiver module.

TD-/+ : These are the differential transmitter inputs. They are AC-coupled, differential lines with 100Ω differential termination inside the module. The AC coupling is done inside the module and is thus not required on the host board.

**EEPROM**

The serial interface uses the 2-wire serial CMOS EEPROM protocol defined for the ATMEL AT24C02/04 family of components. When the serial protocol is activated, the host generates the serial clock signal (SCL). The positive edge clocks data into those segments of the EEPROM that are not write protected within the SFP transceiver. The negative edge clocks data from the SFP transceiver. The serial data signal (SDA) is bi-directional for serial data transfer. The host uses SDA in conjunction with SCL to mark the start and end of serial protocol activation. The memories are organized as a series of 8-bit data words that can be addressed individually or sequentially.

The Module provides diagnostic information about the present operating conditions. The transceiver generates this diagnostic data by digitization of internal analog signals. Calibration and alarm/warning threshold data is written during device manufacture. Received power monitoring, transmitted power monitoring, bias current monitoring, supply voltage monitoring and temperature monitoring all are implemented. If the module is defined as external calibrated, the diagnostic data are raw A/D values and must be converted to real world units using calibration constants stored in EEPROM locations 56 – 95 at wire serial bus address A2H. The digital diagnostic memory map specific data field define as following .For detail EEPROM information, please refer to the related document of SFF 8472 Rev 9.3.

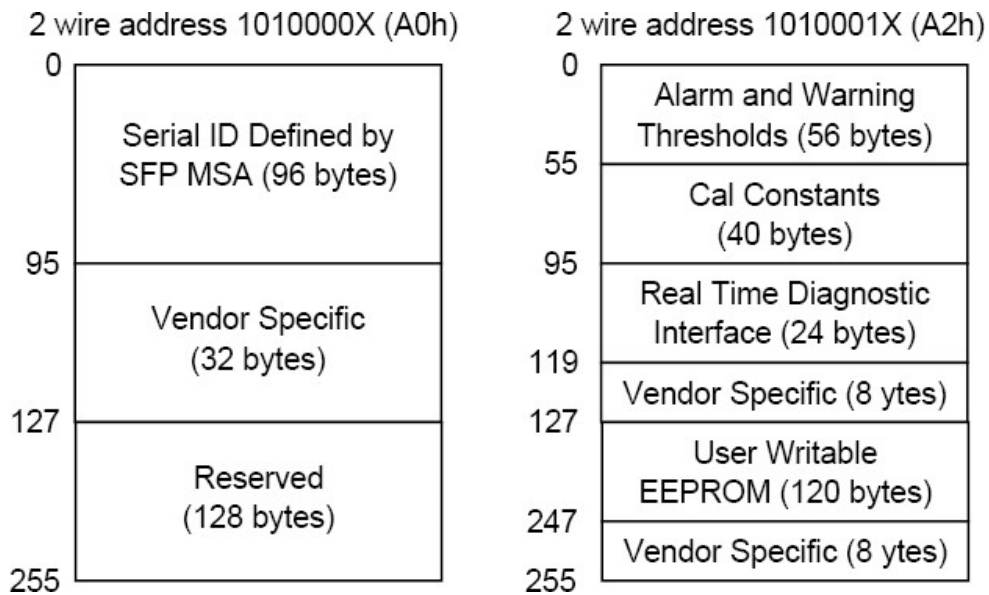



**Recommended Circuit Schematic**

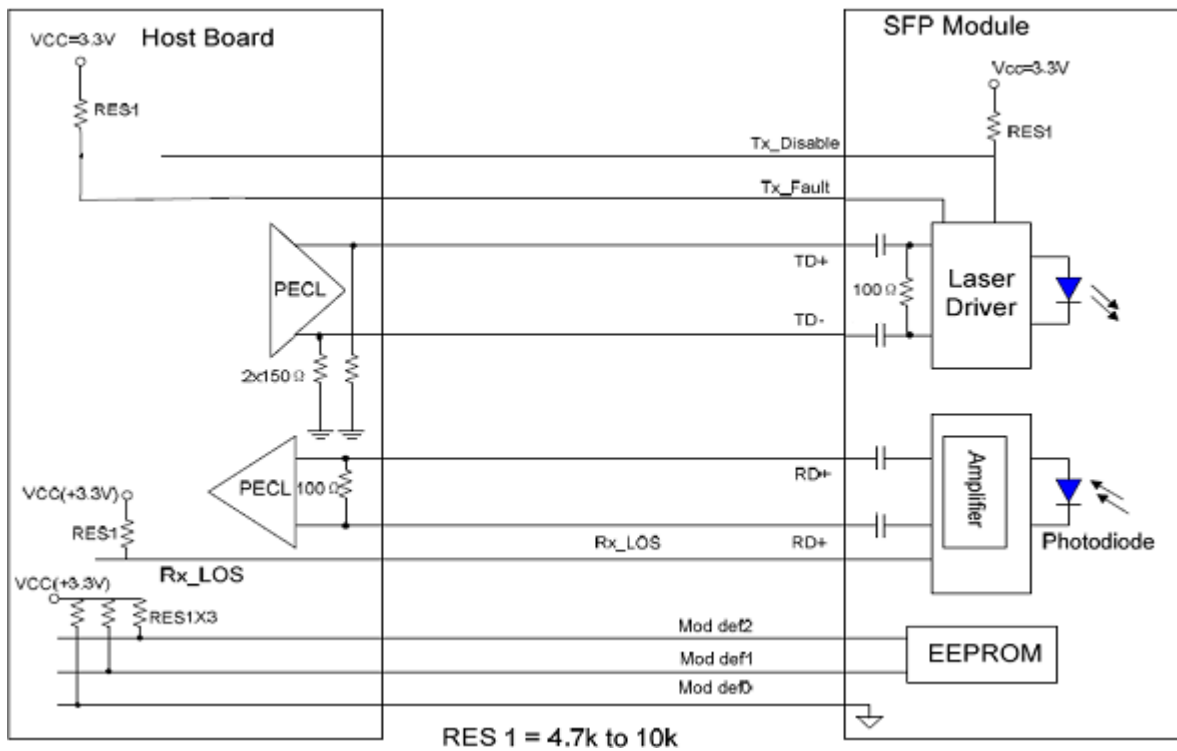

**Mechanical Specifications**

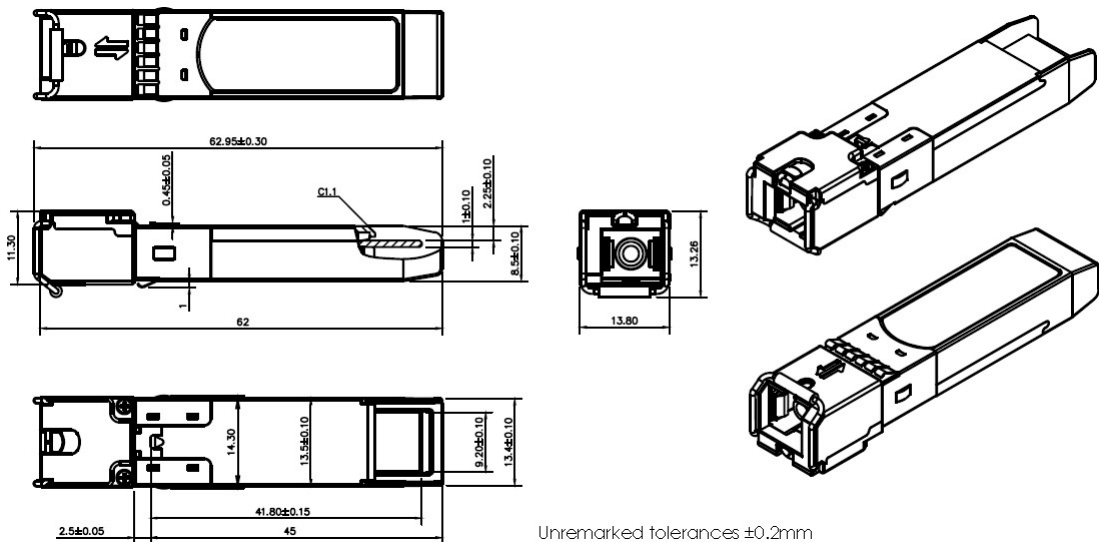

**SC**

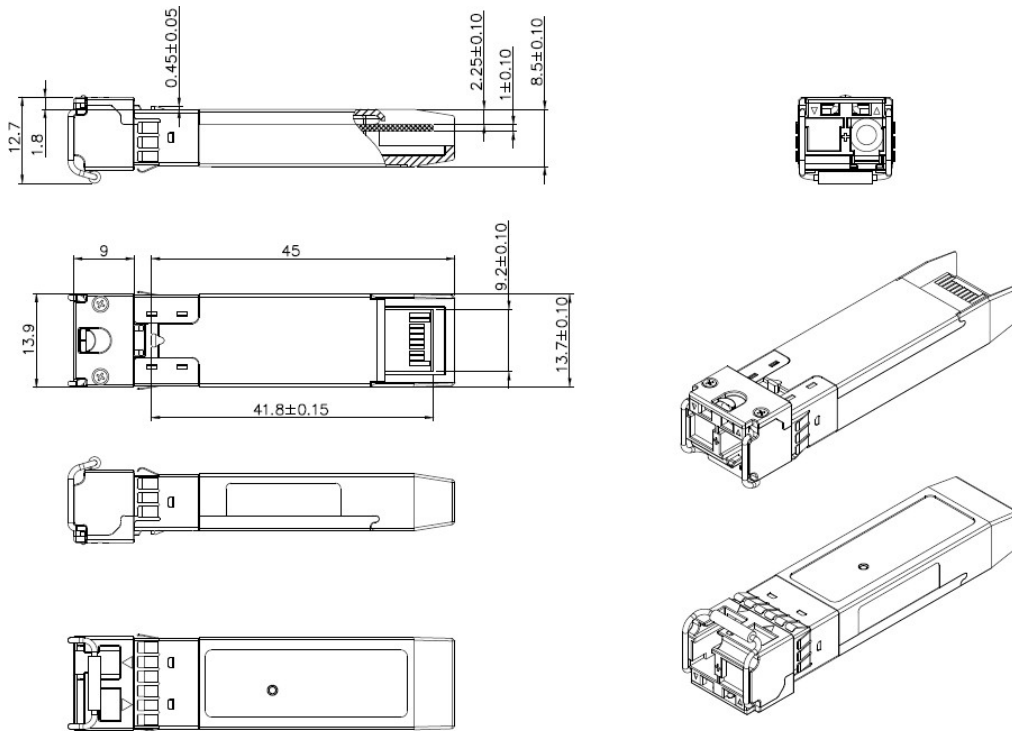

Unremarked tolerances +0.2mm

**LC**

\*This 2D drawing only for reference, please check with Data Controls Inc. before ordering.

**Laser Emission**

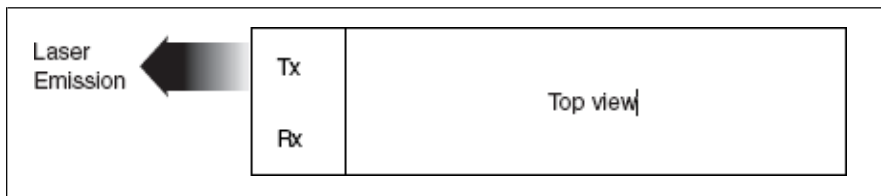

**Obtaining Document**

You can visit our website:

<http://www.dci.jp>

Or contact Data Controls Inc. Listed at the end of the documentation to get the latest document.

**Revision History**

Revision	Revision History	ReleaseDate
V3.a	Released.	Mar 27, 2010
V4.a	Update Recommend Circuit	Aug 10, 2011
V4.b	Change Link Budget and Remove	Aug 22, 2011

EEPROM Information		
V4.c	Change note 6 to multi-rate application	Sept. 5, 2011
V4.d	Update photo	Nov 4, 2011
V4.e	Update the Pout.	June 13, 2013
V4.f	Update the regulatory compliance, eye pattern mask and 2D drawing,	Oct 9,2015
V4.g	Update the regulatory compliance and 2D drawing.	Sept 05,2016

**Notice:**

Data Controls Inc. reserves the right to make changes to or discontinue any optical link product or service identified in this publication, without notice, in order to improve design and/or performance. Applications that are described herein for any of the optical link products are for illustrative purposes only. Data Controls Inc. makes no representation or warranty that such applications will be suitable for the specified use without further testing or modification.

**Contact:**

Add: 8F Fukashiro Bldg., 1-20-4 Yanagibashi, Taito-ku , Tokyo , Japan. Postal: 111-0052

Tel: (+81) 3-5829-5805 Fax: (+81)-3-5829-5806

E-mail:info@dci.jp