



Features

- Compliant with IEEE802.3z Gigabit Ethernet Standard
- Compliant with Fiber Channel 100-SM-LC-L standard
- Compliant with SFF8472 diagnostic monitoring interface
- Industry standard small form pluggable (SFP) package
- Duplex LC connector
- Differential PECL inputs and outputs
- Single power supply 3.3V
- TTL signal detect indicator
- Hot Pluggable
- Class 1 laser product complies with EN 60825-1

Ordering Information

PART NUMBER	WAVELENGTH	INPUT/OUTPUT	SIGNAL DETECT	VOLTAGE	TEMPERATURE
GC1470-SFP-LC.S80	1470 nm	AC/AC	TTL	3.3V	0°C to 70°C
GC1490-SFP-LC.S80	1490 nm	AC/AC	TTL	3.3V	0°C to 70°C
GC1510-SFP-LC.S80	1510 nm	AC/AC	TTL	3.3V	0°C to 70°C
GC1530-SFP-LC.S80	1530 nm	AC/AC	TTL	3.3V	0°C to 70°C
GC1550-SFP-LC.S80	1550 nm	AC/AC	TTL	3.3V	0°C to 70°C
GC1570-SFP-LC.S80	1570 nm	AC/AC	TTL	3.3V	0°C to 70°C
GC1590-SFP-LC.S80	1590 nm	AC/AC	TTL	3.3V	0°C to 70°C
GC1610-SFP-LC.S80	1610 nm	AC/AC	TTL	3.3V	0°C to 70°C

Diagnostics

Parameter	Range	Accuracy	Unit	Calibration
Temperature	-40 to 95	± 3	°C	External
Voltage	0 to VCC	± 0.1	V	
Bias Current	0 to 120	± 5	mA	
TX Power	-3 to +8	± 3 dB	dBm	
RX Power	-24 to -3	± 3 dB	dBm	

Absolute Maximum Ratings

PARAMETER	SYMBOL	MIN	MAX	UNITS	NOTE
Storage Temperature	T_s	-40	85	°C	
Supply Voltage	V_{CC}	-0.5	4.0	V	
Input Voltage	V_{IN}	-0.5	V_{CC}	V	
Output Current	I_o	---	50	mA	
Operating Current	I_{OP}	---	400	mA	

Recommended Operating Conditions

PARAMETER	SYMBOL	MIN	MAX	UNITS	NOTE
Case Operating Temperature	T_C	0	70	°C	
Supply Voltage	V_{CC}	3.1	3.5	V	
Supply Current	$I_{TX} + I_{RX}$	---	300	mA	

Transmitter Electro-optical Characteristics

$V_{cc} = 3.1 \text{ V to } 3.5 \text{ V}$, $T_C = 0^\circ \text{ C to } 70^\circ \text{ C}$

PARAMETER	SYMBOL	MIN	TYP.	MAX	UNITS	NOTE
Output Optical Power 9/125 μm fiber	P_{out}	0	+2	+5	dBm	Average
Extinction Ratio	ER	7	---	---	dB	
Central Wavelength (-N47)	λ_C	1464.5	---	1477.5	nm	
Central Wavelength (-N49)		1484.5	---	1497.5		
Central Wavelength (-N51)		1504.5	---	1517.5		
Central Wavelength (-N53)		1524.5	---	1537.5		
Central Wavelength (-N55)		1544.5	---	1557.5		
Central Wavelength (-N57)		1564.5	---	1577.5		
Central Wavelength (-N59)		1584.5	---	1597.5		
Central Wavelength (-N61)		1604.5	---	1617.5		
Spectral Width (-20dB)	$\Delta\lambda$	---	---	0.8		nm
Side Mode Suppression Ratio	$SMSR$	30	---	---		dB
Rise/Fall Time, (20–80%)	$T_{r, f}$	---	---	260		ps
Relative Intensity Noise	RIN	---	---	-120		dB/Hz
Total Jitter	TJ	---	---	227		ps
Output Eye	Compliant with IEEE802.3z					
Max. P_{out} TX-DISABLE Asserted	P_{OFF}	---	---	-45		dBm
Differential Input Voltage	V_{DIFF}	0.4	---	2.0		V

Receiver Electro-optical Characteristics

$V_{CC} = 3.1 \text{ V to } 3.5 \text{ V}, T_C = 0^\circ \text{ C to } 70^\circ \text{ C}$

PARAMETER	SYMBOL	MIN	TYP.	MAX	UNITS	NOTE
Optical Input Power-maximum	P_{IN}	-1	---	---	dBm	BER < 10^{-12}
Optical Input Power-minimum (Sensitivity)	P_{IN}	---	-27	-24	dBm	BER < 10^{-12}
Operating Center Wavelength	λ_C	1260	---	1620	nm	
Optical Return Loss	ORL	12	---	---	dB	
Signal Detect-Asserted	P_A	---	---	-24	dBm	
Signal Detect-Deasserted	P_D	-40	---	---	dBm	
Differential Output Voltage	V_{DIFF}	0.5	---	1.2	V	
Data Output Rise, Fall Time (20–80%)	$T_{r,f}$	---	---	0.35	ns	
Receiver Loss of Signal Output Voltage-Low	RX_LOS_L	0	---	0.5	V	
Receiver Loss of Signal Output Voltage-High	RX_LOS_H	2.4	---	V_{CC}	V	

Block Diagram of Transceiver

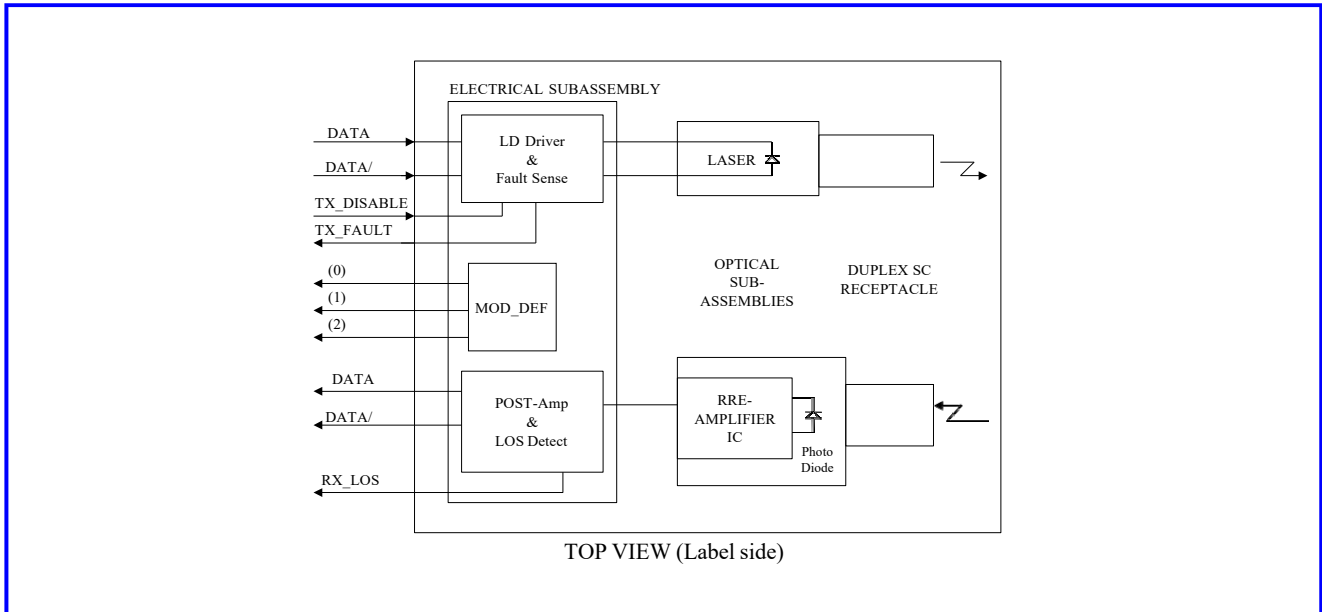

Transmitter Section

The transmitter section consists of a 1550 nm InGaAsP laser in an eye safe optical subassembly (OSA) which mates to the fiber cable. The laser OSA is driven by a LD driver IC which converts differential input LVPECL logic signals into an analog laser driving current.

TX_DISABLE

The TX_DISABLE signal is high (TTL logic “1”) to turn off the laser output. The laser will turn on when TX_DISABLE is low (TTL logic “0”).

Receiver Section

The receiver utilizes an InGaAs PIN photodiode mounted together with a trans-impedance preamplifier IC in an OSA. This OSA is connected to a circuit providing post-amplification quantization, and optical signal detection.

Receive Loss (RX_LOS)

The RX_LOS is high (logic “1”) when there is no incoming light from the companion transceiver. This signal is normally used by the system for the diagnostic purpose. The signal is operated in LVTTTL level.

Dimensions

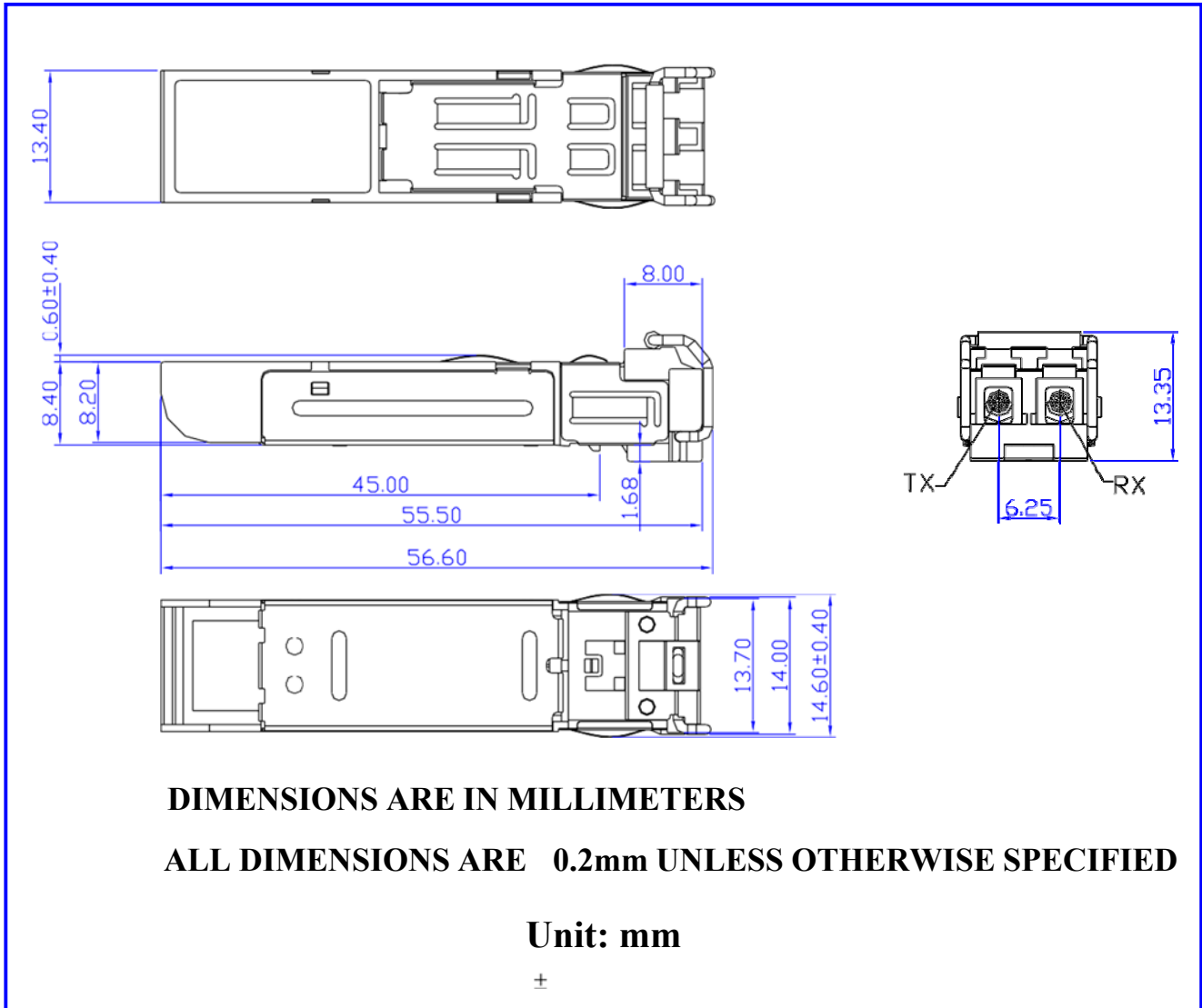

SFP host board mechanical layout

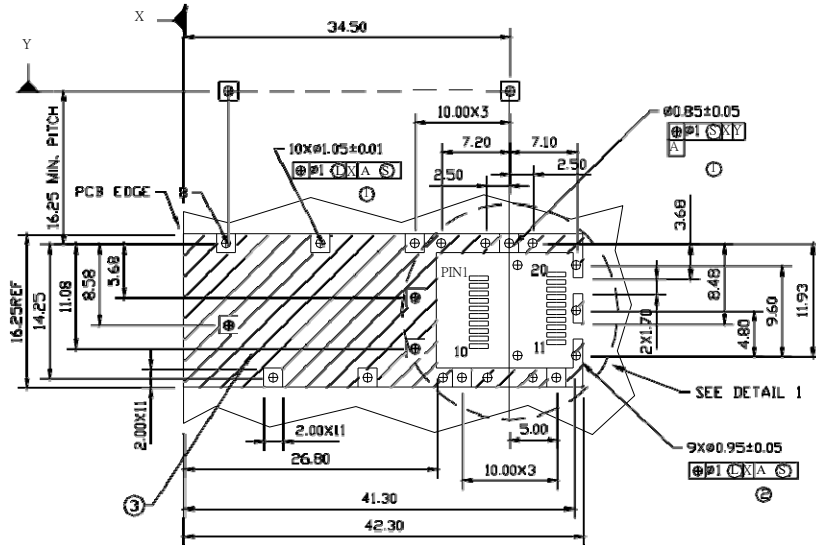

LEGEND

1. PADS AND VIAS ARE CHASSIS GROUND
2. THROUGH HOLES, PLATING OPTIONAL
3. HATCHED AREA DENOTES COMPONENT AND TRACE KEEPOUT (EXCEPT CHASSIS GROUND)
4. AREA DENOTES COMPONENT KEEPOUT (TRACES ALLOWED)

DIMENSIONS ARE IN MILLIMETERS

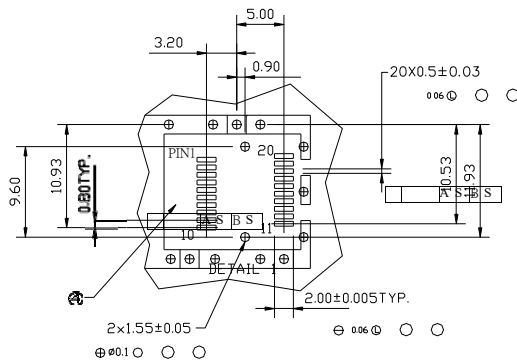

Unit: mm

Assembly drawing

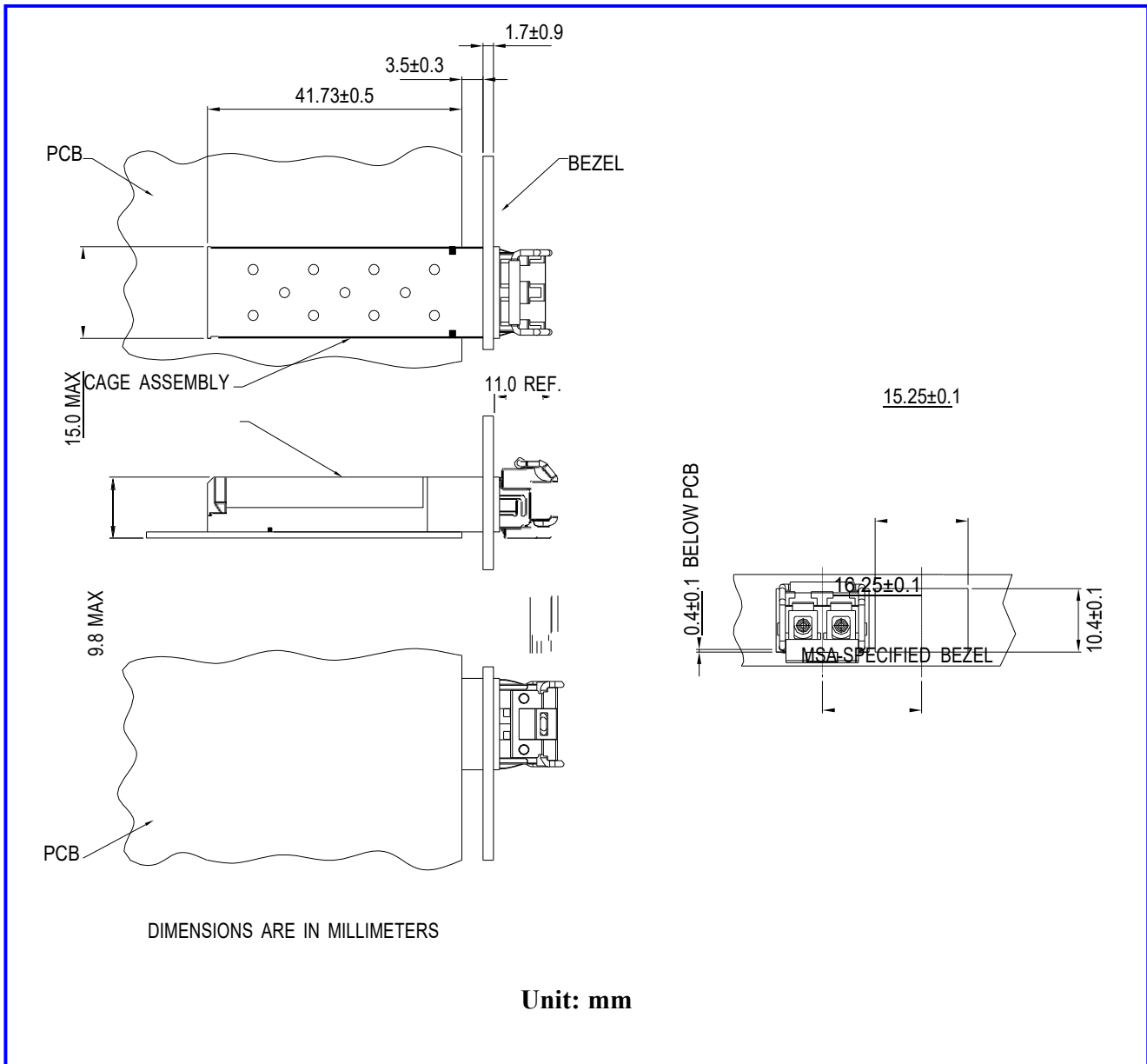

Pin Assignment

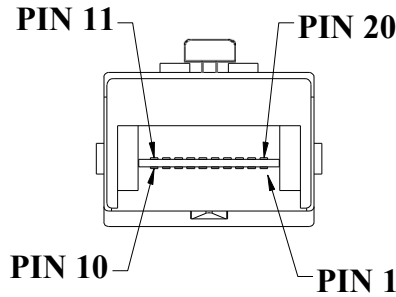

Pin	Signal Name	Description
1	T_{GND}	Transmit Ground
2	TX_FAULT	Transmit Fault
3	$TX_DISABLE$	Transmit Disable
4	$MOD_DEF (2)$	SDA Serial Data Signal
5	$MOD_DEF (1)$	SCL Serial Clock Signal
6	$MOD_DEF (0)$	TTL Low
7	$RATE_SELECT$	Open Circuit
8	RX_LOS	Receiver Loss of Signal, TTL High, open collector
9	R_{GND}	Receiver Ground
10	R_{GND}	Receiver Ground
11	R_{GND}	Receiver Ground
12	$RX-$	Receive Data Bar, Differential PECL, ac coupled
13	$RX+$	Receive Data, Differential PECL, ac coupled
14	R_{GND}	Receiver Ground
15	V_{CCR}	Receiver Power Supply
16	V_{CCT}	Transmitter Power Supply
17	T_{GND}	Transmitter Ground
18	$TX+$	Transmit Data, Differential PCEL, ac coupled
19	$TX-$	Transmit Data Bar, Differential PCEL, ac coupled
20	T_{GND}	Transmitter Ground

Eye Safety Mark

<p>GCxxxx-SFP-LC.S80 series singlemode transceiver is a class 1 laser product. It complies with EN 60825-1 and FDA 21 CFR 1040.10 and 1040.11. In order to meet laser safety requirements the transceiver shall be operated within the Absolute Maximum Ratings.</p> <p>Caution All adjustments have been done at the factory before the shipment of the devices. No maintenance and user serviceable part is required. Tampering with and modifying the performance of the device will result in voided product warranty.</p>	<p>Required Mark</p> <div style="border: 1px solid black; padding: 10px; width: fit-content; margin: 0 auto;"> <p>Class 1 Laser Product Complies with 21 CFR 1040.10 and 1040.11</p> </div>
---	---

Note : All information contained in this document is subject to change without notice.