



### Features

- Compliant with IEEE802.3z Gigabit Ethernet Standard
- Compliant with Fiber Channel 100-SM-LC-L standard
- Compliant with SFF8472 diagnostic monitoring interface
- Industry standard small form pluggable (SFP) package
- Duplex LC connector
- Differential PECL inputs and outputs
- Single power supply 3.3V
- TTL signal detect indicator
- Hot Pluggable
- Class 1 laser product complies with EN 60825-1

### Ordering Information

PART NUMBER	WAVELENGTH	INPUT/OUTPUT	SIGNAL DETECT	VOLTAGE	TEMPERATURE
GC1270-SFP-LC-S.80	1270 nm	AC/AC	TTL	3.3V	0°C to 70°C
GC1290-SFP-LC-S.80	1290 nm	AC/AC	TTL	3.3V	0°C to 70°C
GC1310-SFP-LC-S.80	1310 nm	AC/AC	TTL	3.3V	0°C to 70°C
GC1330-SFP-LC-S.80	1330 nm	AC/AC	TTL	3.3V	0°C to 70°C
GC1350-SFP-LC-S.80	1350 nm	AC/AC	TTL	3.3V	0°C to 70°C
GC1370-SFP-LC-S.80	1370 nm	AC/AC	TTL	3.3V	0°C to 70°C
GC1390-SFP-LC-S.80	1390 nm	AC/AC	TTL	3.3V	0°C to 70°C
GC1410-SFP-LC-S.80	1410 nm	AC/AC	TTL	3.3V	0°C to 70°C
GC1430-SFP-LC-S.80	1430 nm	AC/AC	TTL	3.3V	0°C to 70°C
GC1450-SFP-LC-S.80	1450 nm	AC/AC	TTL	3.3V	0°C to 70°C

### Diagnostics

Parameter	Range	Accuracy	Unit	Calibration
Temperature	-40 to 95	± 3	°C	External
Voltage	0 to VCC	± 0.1	V	
Bias Current	0 to 120	± 5	mA	
TX Power	-3 to +8	± 3 dB	dBm	
RX Power	-24 to -3	± 3 dB	dBm	

### Absolute Maximum Ratings

PARAMETER	SYMBOL	MIN	MAX	UNITS	NOTE
Storage Temperature	$T_s$	-40	85	°C	
Supply Voltage	$V_{CC}$	-0.5	4.0	V	
Input Voltage	$V_{IN}$	-0.5	$V_{CC}$	V	
Output Current	$I_o$	---	50	mA	
Operating Current	$I_{OP}$	---	400	mA	

### Recommended Operating Conditions

PARAMETER	SYMBOL	MIN	MAX	UNITS	NOTE
Case Operating Temperature	$T_C$	0	70	°C	
Supply Voltage	$V_{CC}$	3.1	3.5	V	
Supply Current	$I_{TX} + I_{RX}$	---	300	mA	

### Transmitter Electro-optical Characteristics

$V_{cc} = 3.1 \text{ V to } 3.5 \text{ V}$ ,  $T_c = 0^\circ \text{ C to } 70^\circ \text{ C}$

PARAMETER	SYMBOL	MIN	TYP.	MAX	UNITS	NOTE
Output Optical Power 9/125 $\mu\text{m}$ fiber	$P_{out}$	0	+2	+5	dBm	Average
Extinction Ratio	$ER$	7	---	---	dB	
Central Wavelength (-N27)	$\lambda_c$	1264.5	---	1277.5	nm	
Central Wavelength (-N29)		1284.5	---	1297.5		
Central Wavelength (-N31)		1304.5	---	1317.5		
Central Wavelength (-N33)		1324.5	---	1337.5		
Central Wavelength (-N35)		1344.5	---	1357.5		
Central Wavelength (-N37)		1364.5	---	1377.5		
Central Wavelength (-N39)		1384.5	---	1397.5		
Central Wavelength (-N41)		1404.5	---	1417.5		
Central Wavelength (-N43)		1424.5	---	1437.5		
Central Wavelength (-N45)		1444.5	---	1457.5		
Spectral Width (-20dB)	$\Delta\lambda$	---	---	0.8	nm	
Side Mode Suppression Ratio	$SMSR$	30	---	---	dB	
Rise/Fall Time, (20–80%)	$T_{r,f}$	---	---	260	ps	
Relative Intensity Noise	$RIN$	---	---	-120	dB/Hz	
Total Jitter	$TJ$	---	---	227	ps	
Output Eye IEEE802.3z						Compliant with IEEE802.3z
Max. $P_{out}$ TX-DISABLE Asserted	$P_{OFF}$	---	---	-45	dBm	
Differential Input Voltage	$V_{DIFF}$	0.4	---	2.0	V	

### Receiver Electro-optical Characteristics

$V_{cc} = 3.1 \text{ V to } 3.5 \text{ V}, T_C = 0^\circ \text{ C to } 70^\circ \text{ C}$

PARAMETER	SYMBOL	MIN	TYP.	MAX	UNITS	NOTE
Optical Input Power-maximum	$P_{IN}$	-1	---	---	dBm	BER < $10^{-12}$
Optical Input Power-minimum (Sensitivity)	$P_{IN}$	---	-27	-24	dBm	BER < $10^{-12}$
Operating Center Wavelength	$\lambda_C$	1260	---	1620	nm	
Optical Return Loss	$ORL$	12	---	---	dB	
Signal Detect-Asserted	$P_A$	---	---	-24	dBm	
Signal Detect-Deasserted	$P_D$	-40	---	---	dBm	
Differential Output Voltage	$V_{DIFF}$	0.5	---	1.2	V	
Data Output Rise, Fall Time (20–80%)	$T_{r,f}$	---	---	0.35	ns	
Receiver Loss of Signal Output Voltage-Low	$RX\_LOS_L$	0	---	0.5	V	
Receiver Loss of Signal Output Voltage-High	$RX\_LOS_H$	2.4	---	$V_{CC}$	V	

### Block Diagram of Transceiver

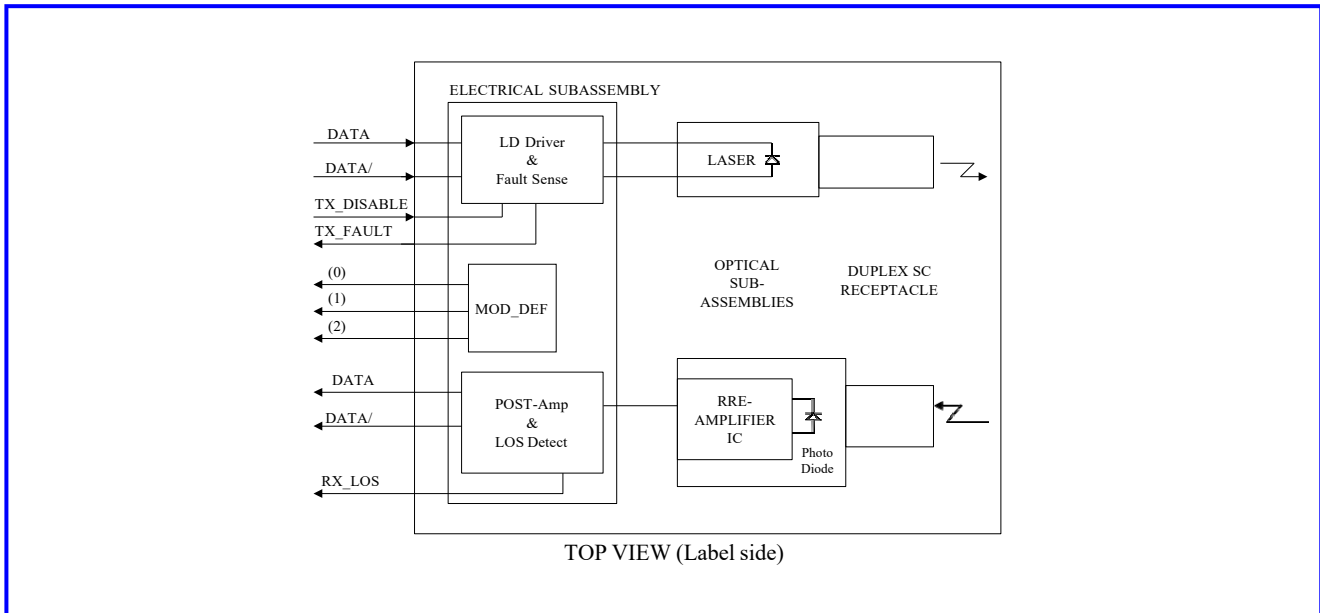

#### Transmitter Section

The transmitter section consists of a 1310 nm InGaAsP laser in an eye safe optical subassembly (OSA) which mates to the fiber cable. The laser OSA is driven by a LD driver IC which converts differential input LVPECL logic signals into an analog laser driving current.

#### TX\_DISABLE

The TX\_DISABLE signal is high (TTL logic “1”) to turn off the laser output. The laser will turn on when TX\_DISABLE is low (TTL logic “0”).

#### Receiver Section

The receiver utilizes an InGaAs PIN photodiode mounted together with a trans-impedance preamplifier IC in an OSA. This OSA is connected to a circuit providing post-amplification quantization, and optical signal detection.

#### Receive Loss (RX\_LOS)

The RX\_LOS is high (logic “1”) when there is no incoming light from the companion transceiver. This signal is normally used by the system for the diagnostic purpose. The signal is operated in LVTTTL level.

### Dimensions

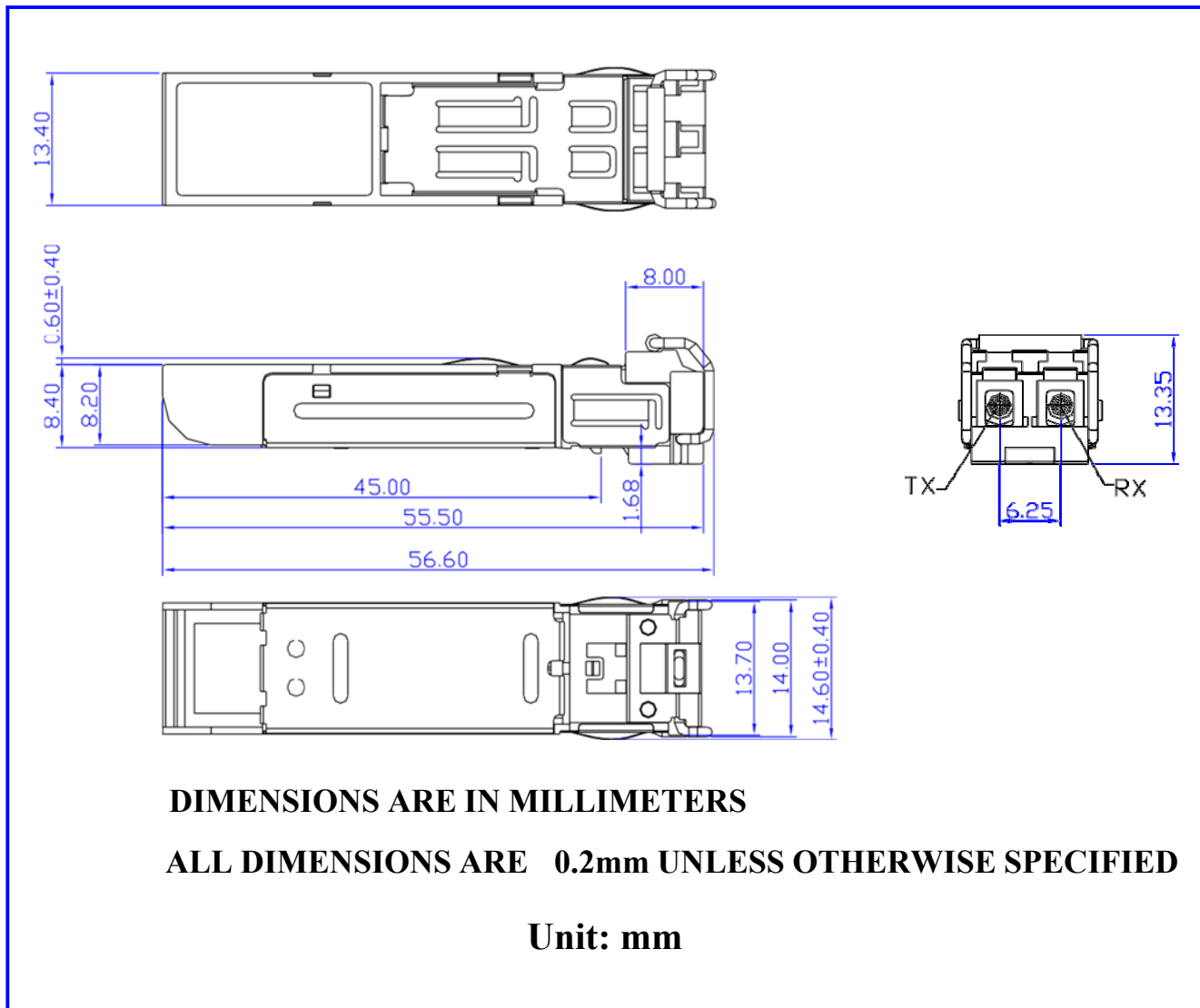

### SFP host board mechanical layout

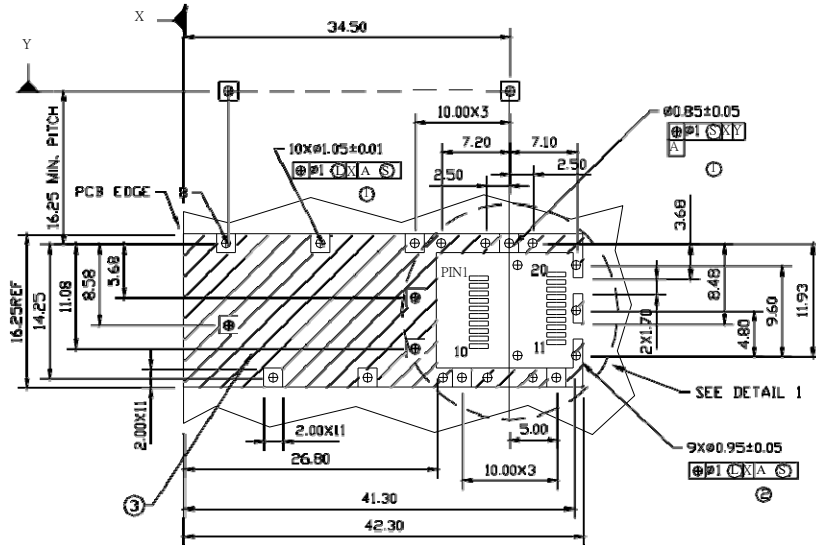

#### LEGEND

1. PADS AND VIAS ARE CHASSIS GROUND
2. THROUGH HOLES, PLATING OPTIONAL
3. HATCHED AREA DENOTES COMPONENT AND TRACE KEEPOUT (EXCEPT CHASSIS GROUND)
4. AREA DENOTES COMPONENT KEEPOUT (TRACES ALLOWED)

DIMENSIONS ARE IN MILLIMETERS

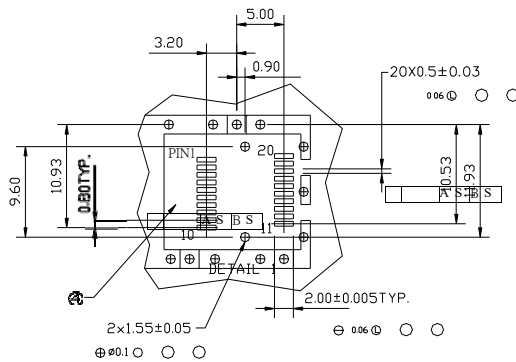

Unit: mm

**Assembly drawing**

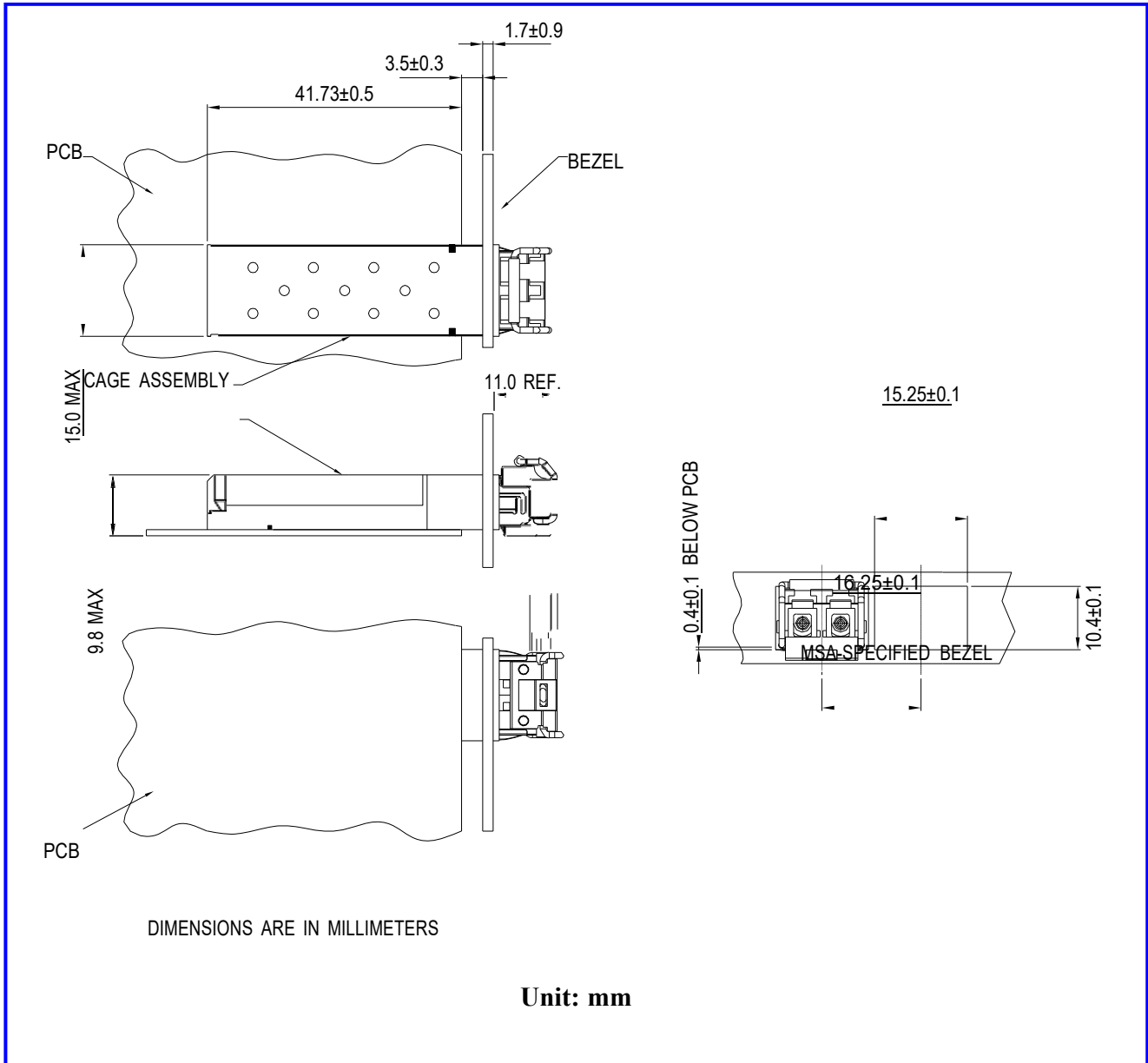



### Pin Assignment

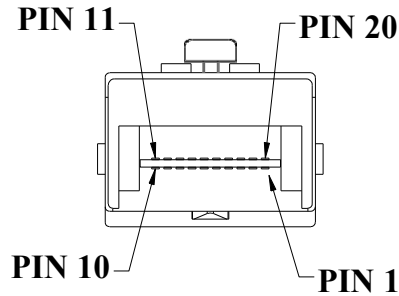

Pin	Signal Name	Description
1	$T_{GND}$	Transmit Ground
2	$TX\_FAULT$	Transmit Fault
3	$TX\_DISABLE$	Transmit Disable
4	$MOD\_DEF (2)$	SDA Serial Data Signal
5	$MOD\_DEF (1)$	SCL Serial Clock Signal
6	$MOD\_DEF (0)$	TTL Low
7	$RATE\_SELECT$	Open Circuit
8	$RX\_LOS$	Receiver Loss of Signal, TTL High, open collector
9	$R_{GND}$	Receiver Ground
10	$R_{GND}$	Receiver Ground
11	$R_{GND}$	Receiver Ground
12	$RX-$	Receive Data Bar, Differential PECL, ac coupled
13	$RX+$	Receive Data, Differential PECL, ac coupled
14	$R_{GND}$	Receiver Ground
15	$V_{CCR}$	Receiver Power Supply
16	$V_{CCT}$	Transmitter Power Supply
17	$T_{GND}$	Transmitter Ground
18	$TX+$	Transmit Data, Differential PCEL, ac coupled
19	$TX-$	Transmit Data Bar, Differential PCEL, ac coupled
20	$T_{GND}$	Transmitter Ground

### Eye Safety Mark

The GCxxx-SFP-LC.S80 series singlemode transceiver is a class 1 laser product. It complies with EN 60825-1 and FDA 21 CFR 1040.10 and 1040.11. In order to meet laser safety requirements the transceiver shall be operated within the Absolute Maximum Ratings.

**Caution**

All adjustments have been done at the factory before the shipment of the devices. No maintenance and user serviceable part is required. Tampering with and modifying the performance of the device will result in voided product warranty.

**Required Mark**

Class 1 Laser Product  
 Complies with  
 21 CFR 1040.10 and 1040.11

Note : All information contained in this document is subject to change without notice.