

GD1000-SFP-RJ/GD1000-SFP-RJ(WT)

1000BASE-T & Serdes interface with RX-LOS Copper SFP Transceiver
RoHS6 Compliant

Features

- ◆ Support 1000BASE-T Operation in Host System
- ◆ For 100m Reach over Cat 5 UTP Cable
- ◆ Hot-Pluggable SFP Footprint
- ◆ Fully Metallic Enclosure for Low EMI
- ◆ Low Power Dissipation (1.05 W Typical)
- ◆ Compact RJ-45 Connector Assembly
- ◆ LOS 1000M Indicator
- ◆ Access to Physical Layer IC via 2-Wire Serial Bus
- ◆ Operating Case Temperature
Standard : 0°C~70°C#
Industrial : -40°C~85°C#
- ◆ Detailed Product Information in EEPROM



Applications

- ◆ LAN 1000Base-T
- ◆ Gigabit Ethernet Over Cat 5 Cable
- ◆ Switch to Switch Interface
- ◆ Router/Server Interface

Order Information

Part No.	Data Rate	Cable type	Distance	Connector	Temp.
GD1000-SFP-RJ <small>*note1</small>	Line side: 1000 BASE-T Host Side : 10/100/1000M with SERDES interface, enable the auto-negotiation, Support Rx_LOS, preferred Master	Cat5	100m	RJ45	Standard
GD1000-SFP-RJ(WT)	Line side: 1000 BASE-T Host Side : 10/100/1000M with SERDES interface, enable the auto-negotiation, Support Rx_LOS, preferred Master	Cat5	100m	RJ45	Industrial

Note1: Standard version

*The product image only for reference purpose.

Regulatory Compliance^{*Note2}

Product Certificate	Certificate Number	Applicable Standard
TUV	R50135086	EN 60950-1:2006+A11+A1+A12+A2
		EN 60825-1:2014
		EN 60825-2:2004+A1+A2
UL	E317337	UL 60950-1
		CSA C22.2 No. 60950-1-07
EMC CE	AE 50285865 0001	EN 55022:2010
		EN 55024:2010
FCC	WTF14F0514417E	47 CFR PART 15 OCT., 2013
FDA	/	CDRH 1040.10
ROHS	/	2011/65/EU

Note2: The above certificate number updated to June 2014, because some certificate will be updated every year, such as FDA and ROHS. For the latest certification information, please check with Data Controls Inc..

Product Description

GD1000-SFP-RJ/GD1000-SFP-RJ(WT) 1000BASE-T Copper Small Form Pluggable (SFP) modules are based on the SFP Multi Source Agreement (MSA). It is compliant with the Gigabit Ethernet standard as specified in IEEE STD 802.3 and can fully satisfy the 1000BASE-T application.

Absolute Maximum Ratings

Parameter	Symbol	Min	Typ	Max
Maximum Supply Voltage	Vcc	-0.5		4.0
Storage Temperature	Ts	-40		85

Normal operating condition

Parameter	Symbol	Min	Typ	Max	Units	Ref.
Operating Temperature	GD1000-SFP-RJ	0		70	°C	
	GD1000-SFP-RJ(WT)	-40		85		
Supply Voltage	Vcc	3.15	3.3	3.45	V	

Electrical Characteristics

Parameter	Symbol	Min	Typ	Max	Units	Notes/Conditions
+3.3 Volt Electrical Power Interface						
Supply Current	I _{cc}		300	350	mA	
Input Voltage	V _{cc}	3.15	3.3	3.45	V	
Surge Current	I _{surge}			30	mA	
Low-Speed Signals, Electronic Characteristics						
SFP Output LOW	V _{OL}	0		0.5	V	4.7k to 10k pull-up to host_Vcc, measured at host side of connector
SFP Output HIGH	V _{OH}	host_Vcc-0.5		host_Vcc+0.3	V	4.7k to 10k pull-up to host_Vcc, measured at host side of connector
SFP Input LOW	V _{IL}	0		0.8	V	4.7k to 10k pull-up to Vcc, measured at SFP side of connector
SFP Input HIGH	V _{IH}	2		V _{cc} + 0.3	V	4.7k to 10k pull-up to Vcc, measured at SFP side of connector
High-Speed Electrical Interface, Transmission Line-SFP						
Line Frequency	f _L		125		MHz	5-level encoding, per IEEE 802.3
TX Output impedance	Z _{out, TX}		100		Ohm	Differential, for all frequencies between 1MHz and 125MHz
RX Input Impedance	Z _{in, RX}		100		Ohm	Differential, for all frequencies between 1MHz and 125MHz
High-Speed Electrical Interface, Host-SFP						
Single ended data input swing	V _{in}	250		1200	mV	Single ended
Single ended data output swing	V _{out}	350		800	mV	Single ended
Rise/Fall Time	T _r , T _f		175		psec	20%-80%
TX Input Impedance	Z _{in}		50		Ohm	Single ended

RX Output Impedance	Zout		50		Ohm	Single ended
---------------------	------	--	----	--	-----	--------------

General specifications

Parameter	Symbol	Min	Typ	Max	Units	Notes/Conditions
Data rate		10		1000	Mbps	
Distance				100	m	Category 5 UTP. BER <10 ⁻¹²

Pin Descriptions

Pin No.	Name	Function	Plug Seq.	Notes
1	VeeT	Transmitter Ground	1	
2	TX Fault	Transmitter Fault Indication	3	Not used
3	TX Disable	Transmitter Disable	3	1
4	MOD-DEF2	Module Definition 2	3	2
5	MOD-DEF1	Module Definition 1	3	2
6	MOD-DEF0	Module Definition 0	3	2
7	Rate Select	Not Connected	3	
8	LOS	Loss of Signal	3	1000M indicator
9	VeeR	Receiver Ground	1	
10	VeeR	Receiver Ground	1	
11	VeeR	Receiver Ground	1	
12	RD-	Inv. Received Data Out	3	
13	RD+	Received Data Out	3	
14	VeeR	Receiver Ground	1	
15	VccR	Receiver Power	2	
16	VccT	Transmitter Power	2	
17	VeeT	Transmitter Ground	1	
18	TD+	Transmit Data In	3	
19	TD-	Inv. Transmit Data In	3	
20	VeeT	Transmitter Ground	1	

Notes:

- PHY disabled on T_{DIS} > 2.0V or open, enabled on T_{DIS} < 0.8V, used to reset the module.
- Should be pulled up with 4.7k – 10k ohm on host board to a voltage between 2.0 V and 3.6 V.
MOD_DEF (0) pulls line low to indicate module is plugged in.

The following is the Diagram of host board connector pin numbers and names

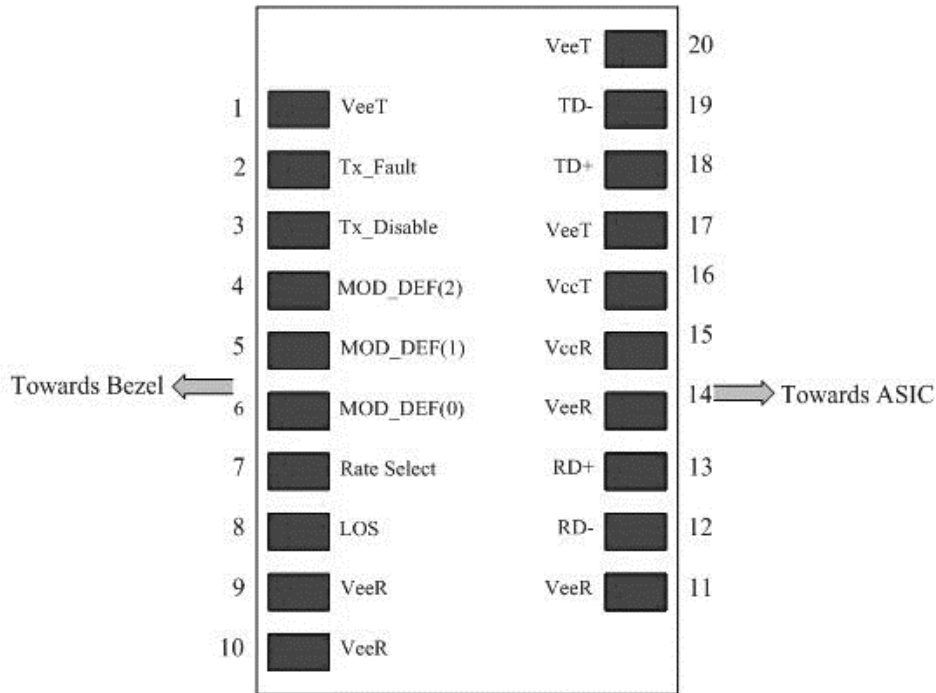

Serial Communication Protocol

Data Controls Inc. Copper SFP support the 2-wire serial communication protocol defined in the SFP MSA. These SFP use a 128 byte EEPROM with an address of A0H. The 1000BASE-T physical layer IC can also be accessed via the 2-wire serial bus at address 0XACH.

EEPROM Serial ID Memory Contents

Accessing Serial ID Memory uses the 2 wire address 1010000X (A0H). Memory Contents of Serial ID are shown in Table 1.

Table 1 Serial ID Memory Contents

Addr.	Size (Bytes)	Name of Field	Hex	Description
BASE ID FIELDS				
0	1	Identifier	03	SFP
1	1	Ext. Identifier	04	SFP function is defined by serial ID only
2	1	Connector	00	
3-10	8	Transceiver	00 00 00 08 00 00 00 00	Transceiver Code
11	1	Encoding	XX ^(note3)	
12	1	BR, Nominal	XX ^(note3)	
13	1	Reserved	00	
14	1	Length (9µm)km		
15	1	Length(9µm)100m		

16	1	Length (50µm) 10m		Transceiver transmit distance
17	1	Length(62.5µm)10 m		
18	1	Length (Copper)	64	100m
19	1	Reserved	00	
20-35	16	Vendor name	XX XX XX XX XX XX XX XX ^(note3) 20 20 20 20 20 20 20 20	Vendor name (ASCII)
36	1	Reserved	00	
37-39	3	Vendor OUI	XX XX XX ^(note3)	
40-55	16	Vendor PN		Transceiver part number
56-59	4	Vendor rev	XX XX XX XX ^(note3)	
60-61	2	Wavelength	00	
62	1	Reserved	00	
63	1	CC_BASE	Check Sum (Variable)	Check code for Base ID Fields
EXTENDED ID FIELDS				
64-65	2	Options	00 00	TX_DISABLE, TX_FAULT and Loss of Signal implemented.
66	1	BR,max	00	
67	1	BR,min	00	
68-83	16	Vendor SN	XX XX XX XX XX XX XX XX 20 20 20 20 20 20 20 20 ^(note3)	Serial Number of transceiver (ASCII). For example "B000822".
84-91	8	Date code	XX XX XX XX XX XX XX XX ^(note3)	Manufacture date code. For example "080405".
92	1	Diagnostic Monitoring Type	XX ^(note3)	Digital diagnostic monitoring implemented
93	1	Enhanced Options	XX ^(note3)	Optional flags
94	1	SFF_8472 Compliance	XX ^(note3)	01 for diagnostics (Rev9.3 SFF-8472).
95	1	CC_EXT	Check Sum (Variable)	Check sum for Extended ID Field.
VENDOR SPECIFIC ID FIELDS				
96-127	32	Vendor Specific	Read only	Depends on customer information
128-255	128	Reserved	Read only	

Note3: The "XX" byte should be filled in according to practical case. For more information, please refer to the related document of SFP Multi-Source Agreement (MSA).

Mechanical Specifications

Data Controls Inc.'s Copper SFP transceivers are compliant with the dimensions defined by the SFP Multi-Sourcing Agreement (MSA).

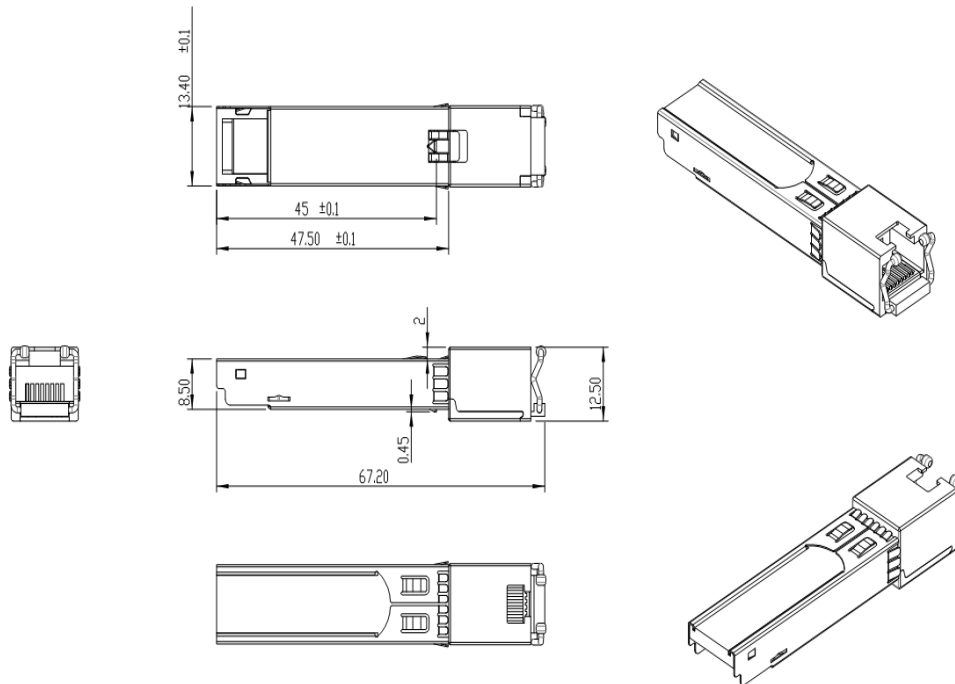

*This 2D drawing only for reference, please check with Data Controls Inc. before ordering.

Obtaining Document

You can visit our website: <http://www.dci.jp>

Or contact Data Controls Inc.. listed at the end of the documentation to get the latest documents.

Revision History

Revision	Revision History	Release Date
V1.a	Released.	April 2018

Notice:

Data Controls Inc. reserves the right to make changes to or discontinue any optical link product or service identified in this publication, without notice, in order to improve design and/or performance. Applications that are described herein for any of the optical link products are for illustrative purposes only. Data Controls Inc. makes no representation or warranty that such applications will be suitable for the specified use without further testing or modification.

Contact:

E-mail: sales@dci.jp <http://www.dci.jp>