

## JD1550-XFP-LC.S40

**1550nm XFP Single-Mode for 10GbE/10GFC/SDH/SONET  
Duplex XFP Transceiver  
RoHS6 Compliant**

### Features

- ◆ Supports 9.95Gb/s to 11.3Gb/s data rates
- ◆ Hot-pluggable XFP Footprint
- ◆ Maximum Link Length up to 40km
- ◆ Temperature-Stabilized EML transmitter
- ◆ Duplex LC Connector
- ◆ Power Dissipation <3.5W
- ◆ Built-in Digital Diagnostic Functions
- ◆ Case Operating Temperature

Standard: 0°C to 70°C



### Applications

- ◆ 10GBASE-ER/EW 10G Ethernet
- ◆ 1200-SM-LL-L 10G Fiber Channel
- ◆ SONET OC-192 IR-2
- ◆ SDH STM S-64.2b
- ◆ SONET OC-192 IR-3
- ◆ SDH STM S-64.3b
- ◆ ITU-T G.709

### Ordering Information

Part No.	Data Rate	Laser	Fiber Type	Distance	Temp.
JD1550-XFP-LC.S40	Up to 11.3Gbps	EML	SMF	40km	Standard

## Regulatory Compliance

Product Certificate	Certificate Number	Applicable Standard
TUV	R50135086	EN 60950-1:2006+A11+A1+A12
		EN 60825-1:2007
		EN 60825-2:2004+A1+A2
UL	E317337	UL 60950-1
		CSA C22.2 No. 60950-1-07
EMC CE	AE 50135430 0001	EN 55022:2006
		EN 55024:1998+A1+A2
CB	JPTUV-024038-M1	IEC 60825-2
		IEC 60950-1
FCC	WTF13F0503735E	47 CFR PART 15 OCT., 2010
	WTF13F0503732E	47 CFR PART 15 OCT., 2010
FDA	1230816-000	CDRH 1040.10
ROHS	RLSZF00163462	2011/65/EU

## Product Description

The JD1550-XFP-LC.S40 single mode transceiver is small form factor pluggable module for duplex optical data communications such as 10GBASE-ER/EW defined by IEEE 802.3ae. It is with the XFP 30-pin connector to allow hot plug capability.

This module is designed for single mode fiber and operates at a nominal wavelength of 1550 nm. The transmitter section uses a 1550nm EML, which is class 1 laser compliant according to International Safety Standard IEC-60825.

The receiver section uses an integrated InGaAs detector preamplifier (IDP) mounted in an optical header and a limiting post-amplifier IC.

## Absolute Maximum Ratings

Parameter	Symbol	Min	Typ	Max	Unit
Maximum Supply Voltage 1	Vcc3	-0.5		4.0	V
Maximum Supply Voltage 2	Vcc5	-0.5		6.0	V
Storage Temperature	Ts	-40		85	°C

**Recommended Operating Condition**

Parameter	Symbol	Min	Typ	Max	Units
Operating Case Temperature	T <sub>c</sub>	0		70	°C
Supply Voltage 1	V <sub>cc3</sub>	3.13	3.3	3.45	V
Supply Voltage 2	V <sub>cc5</sub>	4.75	5	5.25	V

**Electrical Characteristics**

Parameter	Symbol	Min	Typ	Max	Unit
Main Supply Voltage	V <sub>cc5</sub>	4.75		5.25	V
Supply Voltage #2	V <sub>cc3</sub>	3.13		3.45	V
Supply Current – V <sub>cc5</sub> supply	I <sub>cc5</sub>			370	mA
Supply Current – V <sub>cc3</sub> supply	I <sub>cc3</sub>			500	mA
Module Total Power	P			3.5	W
<b>Transmitter</b>					
Input Differential Impedance* <sup>Note1</sup>	R <sub>in</sub>		100		Ω
Differential Data Input Swing	V <sub>in,pp</sub>	120		820	mV
Transmit Disable Voltage	V <sub>D</sub>	2.0		V <sub>cc</sub>	V
Transmit Enable Voltage	V <sub>EN</sub>	GND		GND+ 0.8	V
Transmit Disable Assert Time				10	us
<b>Receiver</b>					
Differential Data Output Swing	V <sub>out,pp</sub>	340	650	850	mV
Rise Time (20– 80%)* <sup>Note2</sup>	t <sub>r</sub>			38	ps
Fall Time (20– 80%)* <sup>Note2</sup>	t <sub>f</sub>			39	ps
LOS Fault* <sup>Note3</sup>	V <sub>LOS fault</sub>	V <sub>cc</sub> – 0.5		V <sub>cc</sub> HOST	V
LOS Normal* <sup>Note3</sup>	V <sub>LOS norm</sub>	GND		GND+0.5	V

Note1: After internal AC coupling

Note2: Loss Of Signal is open collector to be pulled up with a 4.7k – 10k ohm resistor to 3.15 – 3.6V. Logic 0 indicates normal operation; logic 1 indicates no signal detected.

Note3: Per Section 2.7.1. in the XFP MSA Specification.

**Optical Characteristics**

Parameter	Symbol	Min	Typ	Max	Unit
Date Rate	BR	9.95	10.3	11.3	Gbps
<b>Transmitter</b>					
Optical Modulation Amplitude	P		-2.1		dBm
Output Opt. Pwr: 9/125 SMF	P <sub>out</sub>	0		+4	dBm
Optical Wavelength	λ <sub>c</sub>	1530		1565	nm
Optical Extinction Ratio@10.3Gb/s	ER	8.2			dB
Transmitter and Dispersion Penalty	TDP			2	dB
Average Launch Power of OFF	P <sub>OFF</sub>			-30	dBm

Transmitter					
TX Jitter Generation (Peak-to-Peak)	TXj			0.1	UI
TX Jitter Generation (RMS)	TXjRMS			0.01	UI
<b>Receiver</b>					
Receiver Sensitivity@10.3Gb/s	Pmin			-16	dBm
Maximum Input Power	Pmax	0			dBm
Optical Center Wavelength	$\lambda_c$	1270	1550	1600	nm
Receiver Reflectance	Rrx			-27	dB
LOS De-Assert	LOSD			-18	dBm
LOS Assert	LOSA	-30			dBm
LOS Hysteresis		1			dB

## Pin Descriptions

Pin	Logic	Symbol	Name/Description	Ref.
1		GND	Module Ground	1
2		VEE5	Optional -5.2 Power Supply – Not required	
3	LVTTL-I	Mod-Desel	Module De-select; When held low allows the module to respond to 2-wire serial interface commands	
4	LVTTL-O	Interrupt	Interrupt (bar); Indicates presence of an important condition which can be read over the serial 2-wire interface	2
5	LVTTL-I	TX_DIS	Transmitter Disable; Transmitter laser source turned off	
6		VCC5	+5 Power Supply	
7		GND	Module Ground	1
8		VCC3	+3.3V Power Supply	
9		VCC3	+3.3V Power Supply	
10	LVTTL-I	SCL	Serial 2-wire interface clock line	2
11	LVTTL-I/O	SDA	Serial 2-wire interface data line	2
12	LVTTL-O	Mod_Abs	Module Absent; Indicates module is not present. Grounded in the module.	2
13	LVTTL-O	Mod_NR	Module Not Ready;	2
14	LVTTL-O	RX_LOS	Receiver Loss of Signal indicator	2
15		GND	Module Ground	1
16		GND	Module Ground	1
17	CML-O	RD-	Receiver inverted data output	
18	CML-O	RD+	Receiver non-inverted data output	
19		GND	Module Ground	1
20		VCC2	+1.8V Power Supply – Not required	
21	LVTTL-I	P_Down/RST	Power Down; When high, places the module in the low power stand-by mode and on the falling edge of	

			P_Down initiates a module reset	
			Reset; The falling edge initiates a complete reset of the module including the 2-wire serial interface, equivalent to a power cycle.	
22		VCC2	+1.8V Power Supply – Not required	
23		GND	Module Ground	1
24	PECL-I	RefCLK+	Reference Clock non-inverted input, AC coupled on the host board – Not required	3
25	PECL-I	RefCLK-	Reference Clock inverted input, AC coupled on the host board – Not required	3
26		GND	Module Ground	1
27		GND	Module Ground	1
28	CML-I	TD-	Transmitter inverted data input	
29	CML-I	TD+	Transmitter non-inverted data input	
30		GND	Module Ground	1

### Notes:

1. Module circuit ground is isolated from module chassis ground within the module.
2. Open collector; should be pulled up with 4.7k – 10k ohm on host board to a voltage between 3.15V and 3.6V.
3. A Reference Clock input is not required.

### Hostboard Connector Pinout

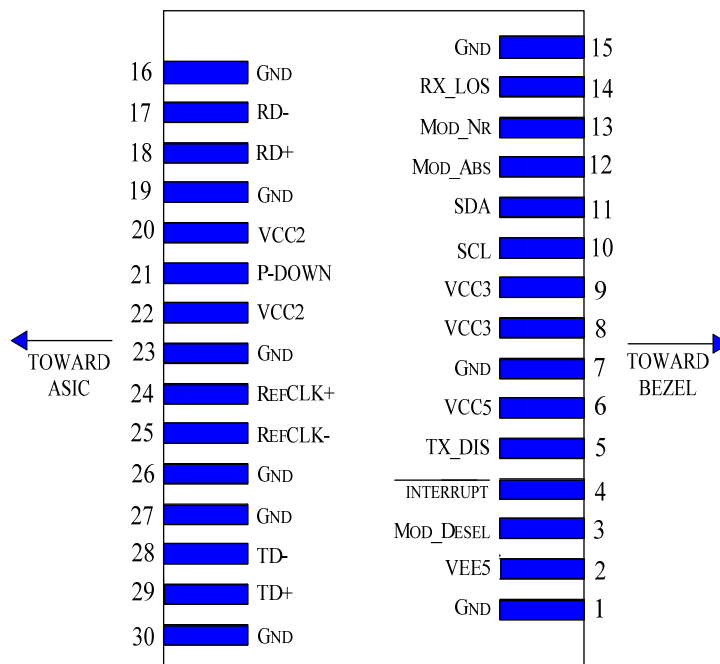

## Digital Diagnostic Functions

JD1550-XFP-LC.S40 Small Form Factor 10Gb/s (XFP) transceivers are compliant with the current XFP Multi-Source Agreement (MSA) Specification Rev 4.5.

As defined by the XFP MSA, our XFP transceivers provide digital diagnostic functions via a 2-wire serial interface, which allows real-time access to the following operating parameters:

- ◆ Transceiver temperature
- ◆ Laser bias current
- ◆ Transmitted optical power
- ◆ Received optical power
- ◆ Transceiver supply voltage

It also provides a sophisticated system of alarm and warning flags, which may be used to alert end-users when particular operating parameters are outside of a factory-set normal range.

The operating and diagnostics information is monitored and reported by a Digital Diagnostics Transceiver Controller inside the transceiver, which is accessed through the 2-wire serial interface. When the serial protocol is activated, the serial clock signal (SCL pin) is generated by the host. The positive edge clocks data into the XFP transceiver into those segments of its memory map that are not write-protected. The negative edge clocks data from the XFP transceiver. The serial data signal (SDA pin) is bi-directional for serial data transfer. The host uses SDA in conjunction with SCL to mark the start and end of serial protocol activation. The memories are organized as a series of 8-bit data words that can be addressed individually or sequentially. The 2-wire serial interface provides sequential or random access to the 8 bit parameters, addressed from 000h to the maximum address of the memory.

## Recommended Host Board Power Supply Circuit

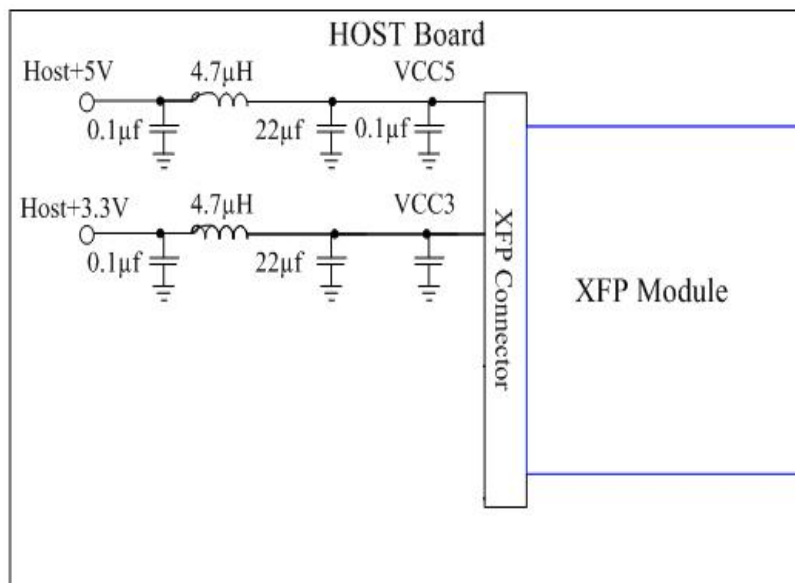

Recommended High-Speed Interface Circuit

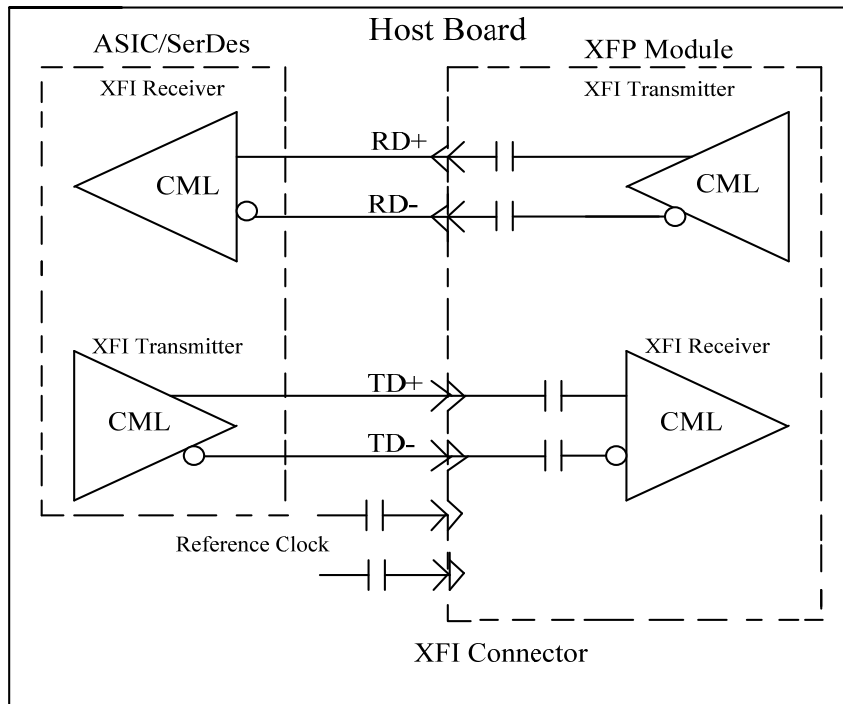

Mechanical Specifications

DCI's XFP transceivers are compliant with the dimensions defined by the XFP Multi-Sourcing Agreement (MSA).

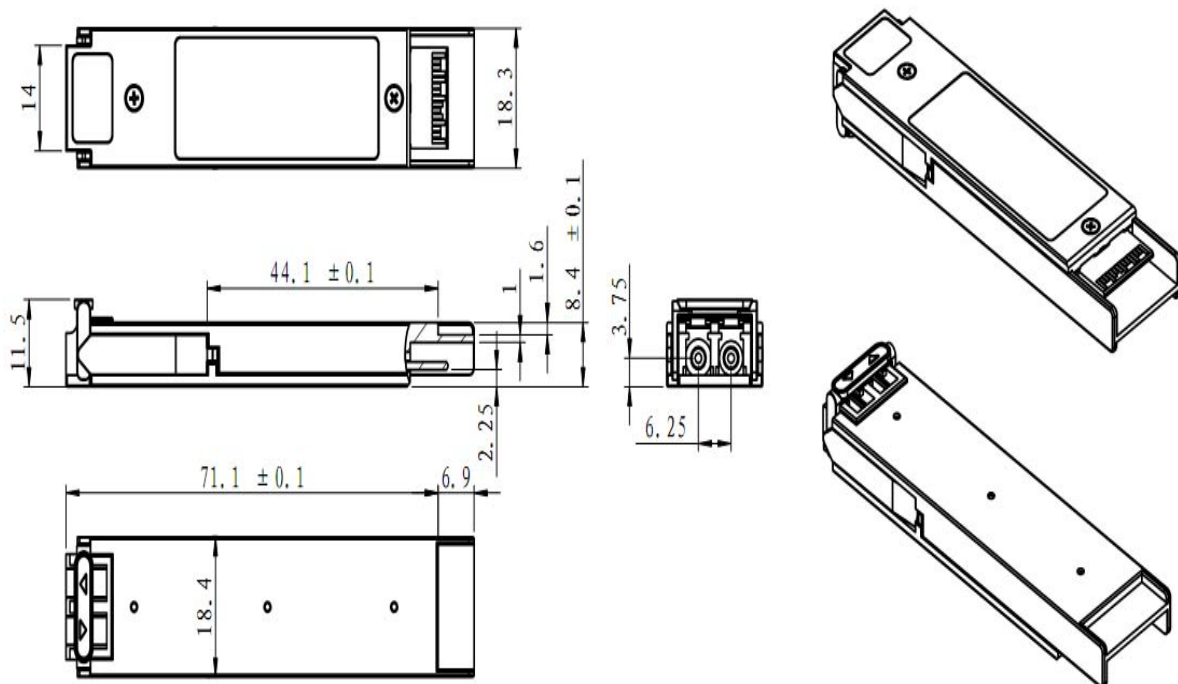

**Eye Safety**

This single-mode transceiver is a Class 1 laser product. It complies with IEC-60825 and FDA 21 CFR 1040.10 and 1040.11. The transceiver must be operated within the specified temperature and voltage limits. The optical ports of the module shall be terminated with an optical connector or with a dust plug.