

Features

- Compliant with 40G Ethernet IEEE 802.3ba 40GBASE SR4 standards
- Single 3.3V and high speed AC-Coupled
- Supports Infiniband SDR, DDR and QDR
- Wide Operating Temperature (0°C ~ 70°C)

Applications

- Data Center Backbone
- Ethernet Switches
- High-speed Servers
- High-performance Computing Clusters
- SAN, Routers, Hubs, Load Balancer

Absolute Maximum Ratings

Parameter	Symbol	Min.	Max.	Units	Note
Storage Temperature	T_s	0	+85	°C	
Relative Humidity	RH	0	+85	%	

Recommended Operating Conditions

Parameter	Symbol	Min.	Typ.	Max.	Units
Case Operating Temperature	T_c	0	40	70	°C
Power Supply Voltage	V_{cc}	3.15	3.3	3.45	V
Signaling Rate each Channel		2.5		10.3125	Gbps
Two Wire Serial (TWS) Interface Clock Rate		---	---	400	kHz
Power Supply Noise		---	---	50	mVpp
Supply Noise Rejection		---	---	100	mV
Receiver Differential Data Output		---	100		Ohm
Operating Distance	D	---	3	---	m

Electrical Characteristics
T=25°C, unless noted

Parameter	Symbol	Min.	Typ.	Max.	Units
Power Consumption		0.8		1.1	W
Supply Current				320	mA
Initialization				200	ms

Transmitter Characteristics
T=25°C, unless noted

Parameter	Symbol	Min.	Typ.	Max.	Units
Differential input impedance	R_{IN}	---	100	---	Ohm
Differential data input swing	$V_{IN,PP}$	180		1000	mV

Receiver Characteristics
T=25°C, unless noted

Parameter	Symbol	Min.	Typ.	Max.	Units
Differential Output impedance	R_{OUT}	---	100	---	Ohm
Differential Output swing	$V_{OUT,PP}$	300		850	mV
Output Total Jitter				60	ps

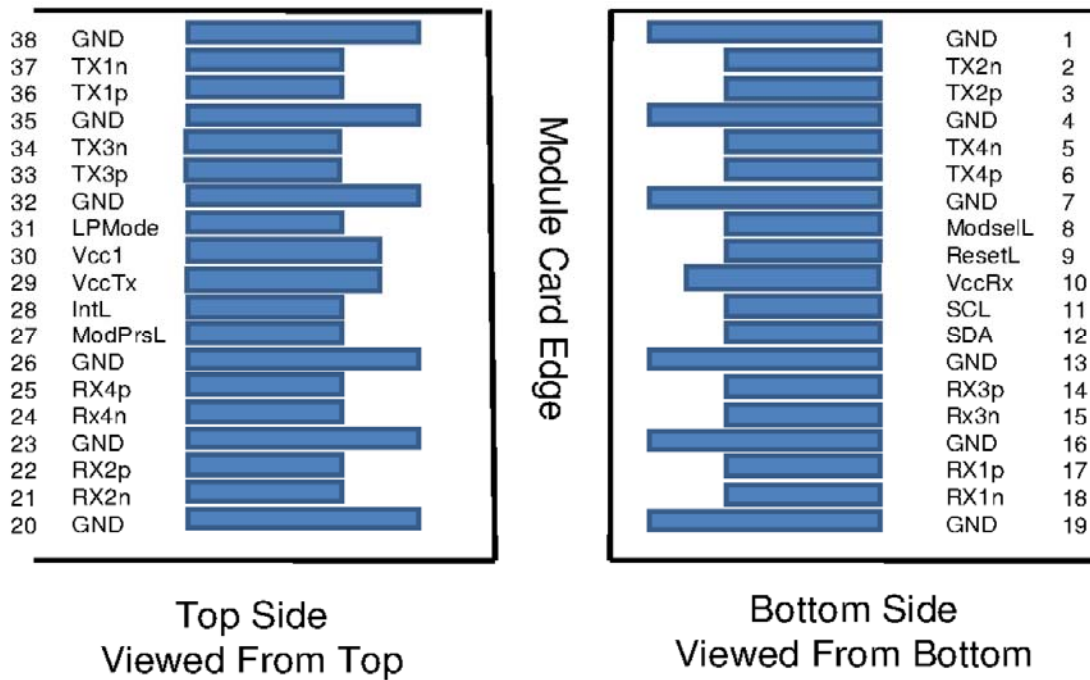
Pin Assignment

Pin Description

PIN	Logic	Symbol	Name/Description	Note
1		GND	Ground	1
2	CML-I	Tx2n	Transmitter Inverted Data Input	
3	CML-I	Tx2p	Transmitter Non-Inverted Data output	
4		GND	Ground	1
5	CML-I	Tx4n	Transmitter Inverted Data Input	
6	CML-I	Tx4p	Transmitter Non-Inverted Data output	
7		GND	Ground	1
8	LVTTL-I	ModSelL	Module Select	
9	LVTTL-I	ResetL	Module Reset	
10		VccRx	+ 3.3V Power Supply Receiver	2
11	LVCMOS-I/O	SCL	2-Wire Serial Interface Clock	
12	LVCMOS-I/O	SDA	2-Wire Serial Interface Data	
13		GND	Ground	
14	CML-O	Rx3p	Receiver Non-Inverted Data Output	
15	CML-O	Rx3n	Receiver Inverted Data Output	
16		GND	Ground	1
17	CML-O	Rx1p	Receiver Non-Inverted Data Output	
18	CML-O	Rx1n	Receiver Inverted Data Output	
19		GND	Ground	1
20		GND	Ground	1
21	CML-O	Rx2n	Receiver Inverted Data Output	
22	CML-O	Rx2p	Receiver Non-Inverted Data Output	
23		GND	Ground	1
24	CML-O	Rx4n	Receiver Inverted Data Output	1
25	CML-O	Rx4p	Receiver Non-Inverted Data Output	
26		GND	Ground	1
27	LVTTL-O	ModPrsL	Module Present	
28	LVTTL-O	IntL	Interrupt	
29		VccTx	+3.3 V Power Supply transmitter	2
30		Vcc1	+3.3 V Power Supply	2
31	LVTTL-I	LPMODE	Low Power Mode	
32		GND	Ground	1

PIN	Logic	Symbol	Name/Description	Note
33	CML-I	Tx3p	Transmitter Non-Inverted Data Input	
34	CML-I	Tx3n	Transmitter Inverted Data Output	
35		GND	Ground	1
36	CML-I	Tx1p	Transmitter Non-Inverted Data Input	
37	CML-I	Tx1n	Transmitter Inverted Data Output	
38		GND	Ground	1

Dimensions

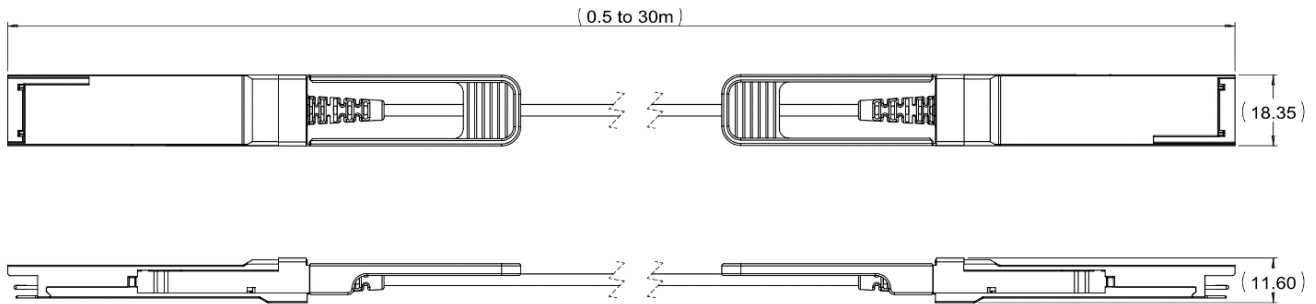



Ordering Information



Part Number	Model Number	Length (M)	Voltage	Temperature
AOC-OM3-QSFP-1M	Active Optical Cable,OM3,QSFP+	1	3.3V	0°C ~ 70°C

Note: All information contained in this document is subject to change without notice.

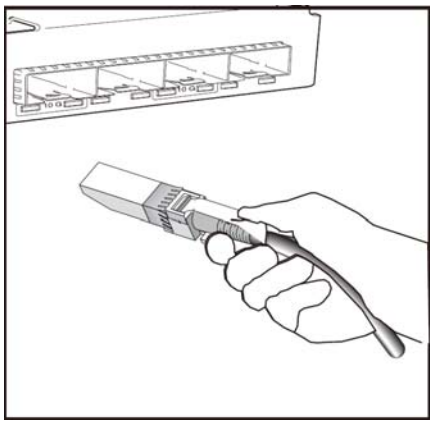
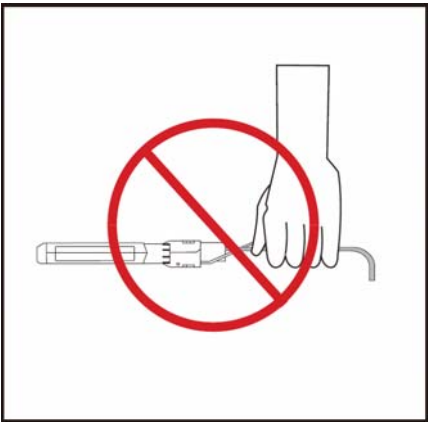
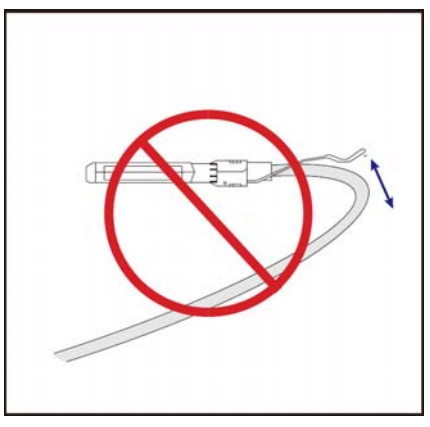
Important Notice

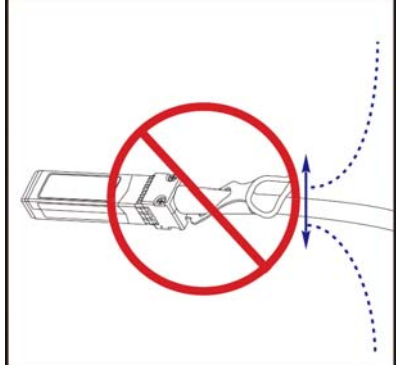
		
<p>Holding the SFP+ connector by its sides, insert the connector into the port on the switch</p>	<p>Do not handle by cable</p>	<p>DO NOT Over-bend the cable behind the connector</p>
		
<p>DO NOT twist the cable</p>	<p>DO NOT kink the cable</p>	<p>DO NOT bend up and down the cable</p>